

Physics 2019 (Outside Delhi)

SET I

Time allowed : 3 hours

Maximum marks : 70

General Instructions :

- (i) All questions are compulsory. There are 27 questions in all.
- (ii) This question paper has four sections: Section A, Section B, Section C, and Section D.
- (iii) Section A contains five questions of one mark each, Section B contains seven questions of two marks each, Section C contains twelve questions of three marks each, Section D contains three questions of five marks each.
- (iv) There is no overall choice. However, an internal choice (s) has been provided in two questions of one mark, two questions of two marks, four questions of three marks and three questions of five marks weightage. You have to attempt only one of the choices in such questions.
- (v) You may use the following values of physical constants wherever necessary :

$$c = 3 \times 10^8 \text{ m/s}$$

$$h = 6.63 \times 10^{-34} \text{ Js}$$

$$e = 1.6 \times 10^{-19} \text{ C}$$

$$\mu_0 = 4\pi \times 10^{-7} \text{ T m A}^{-1}$$

$$\epsilon_0 = 8.854 \times 10^{-12} \text{ C}^2 \text{ N}^{-1} \text{ m}^{-2}$$

$$\frac{1}{4\pi\epsilon_0} = 9 \times 10^9 \text{ N m}^2 \text{ C}^{-2}$$

Mass of electron (m_e) = $9.1 \times 10^{-31} \text{ kg}$

Mass of neutron = $1.675 \times 10^{-27} \text{ kg}$

Mass of proton = $1.673 \times 10^{-27} \text{ kg}$

Avogadro's number = 6.023×10^{23} per gram mole

Boltzmann constant = $1.38 \times 10^{-23} \text{ JK}^{-1}$

SECTION-A

1. Draw equipotential surfaces for an electric dipole. [1]

Answer :

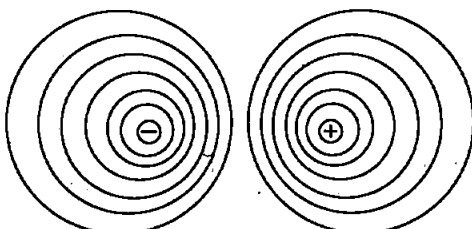

Equipotential surface for an electric dipole.

2. A proton is accelerated through a potential difference V , subjected to a uniform magnetic field acting normal to the velocity of the proton. If the potential difference is doubled, how will the radius of the circular path described by the proton in the magnetic field change? [1]

Answer :

Given, proton accelerated through potential difference V , the direction of magnetic field is normal to velocity of proton.

As we know

$$\frac{1}{2} m_p v^2 = eV$$

[during acceleration of proton, P.E. will converted to kinetic energy]

$$v = \sqrt{\frac{2eV}{m_p}}$$

When V is doubled,

$$V' = 2V,$$

$$\therefore v' = \sqrt{\frac{2e \cdot 2V}{m_p}} = \sqrt{2} v$$

$$qvB = \frac{m_p v}{r}$$

$$\Rightarrow r = \frac{m_p v}{qB}$$

$$\Rightarrow r' = \frac{m_p v'}{qB}$$

$$\Rightarrow r' = \frac{m_p}{qB} \sqrt{2} v$$

$$\therefore r' = \sqrt{2} r$$

3. The magnetic susceptibility χ of magnesium at 300 K is 1.2×10^5 . At what temperature will its magnetic susceptibility become 1.44×10^5 ? [1]

OR

The magnetic susceptibility χ of a given material is -0.5 . Identify the magnetic material.

Answer :

Given, χ_{mg} at 300 K = 1.2×10^5

$$\chi'_{mg} \text{ at } t \text{ temp.} = 1.44 \times 10^5$$

$$t = ?$$

From Curies law www.cbsepdf.com No OTP No Login No Adversitement

$$\chi \propto \frac{1}{T}$$

$$\frac{\chi'_{mg}}{\chi_{mg}} = \frac{300}{t}$$

$$\Rightarrow \frac{1.44 \times 10^5}{1.2 \times 10^5} = \frac{300}{t}$$

$$t = \frac{300 \times 1.2}{1.44}$$

$$= 250 \text{ K}$$

OR

Diamagnetic as $1 < \chi < 0$.

4. Identify the semiconductor diode whose V-I characteristics are as shown. [1]

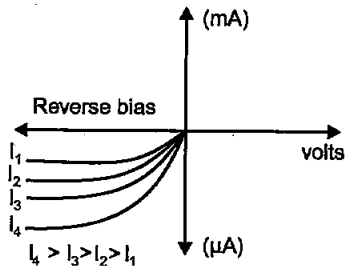

Answer : Photodiode.

5. Which part of the electromagnetic spectrum is used in RADAR? Give its frequency range. [1]

OR

How are electromagnetic waves produced by accelerating charges ?

Answer : Microwaves [1GHz to 100 GHz].

OR

An oscillating electric field in space, produces an oscillating magnetic field, which in turn, is a source of oscillating electric field, and so on. The oscillating electric and magnetic fields thus regenerate each other.

SECTION B

6. A capacitor made of two parallel plates, each of area 'A' and separation 'd' is charged by an external d.c.-source. Show that during charging, the displacement current inside the capacitor is the same as the current charging the capacitor. [2]

Answer :

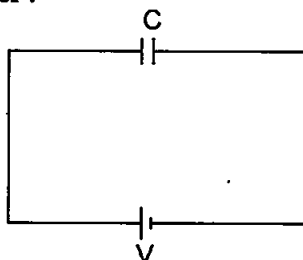

From Ampere's law,

$$\oint \vec{B} dl = \mu_0 i(t)$$

Let the case-1, where a point P is considered outside the capacitor charging.

From Ampere's law magnetic field at point P will be :

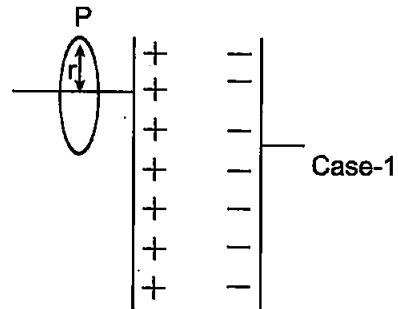

Case-1

$$B.(2\pi r) = \mu_0 i'(t)$$

$$B = \frac{\mu_0 i}{2\pi r}(t)$$

Now, take case-2 where shape of surface under consideration covers capacitor's plate as we consider there is no current through capacitor then this value of B will be zero.

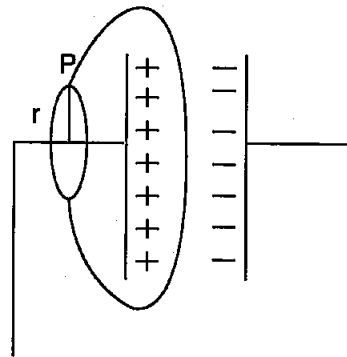

Case-2

Hence, there is a contradiction.

Therefore, this Ampere's law was modified with addition of displacement current inside capacitor.

$$\phi_E = |E| A = \frac{1}{\epsilon_0} \cdot \frac{Q}{A} \cdot A = \frac{Q}{\epsilon_0}$$

$$\frac{d\phi_E}{dt} = \frac{1}{\epsilon_0} \cdot \frac{dQ}{dt}$$

$$\epsilon_0 \frac{d\phi_E}{dt} = \frac{dQ}{dt} = i_d$$

Where, i_d is displacement current.

During charging of capacitor, outside the capacitor, i_c (conduction current) flows and inside i_d (displacement current) flows.

$$i = i_c + i_d = i_c + \epsilon_0 \frac{d\phi_E}{dt}$$

outside the capacitor, $i_d = 0$ hence, $i = i_c$

and inside the capacitor, $i_c = 0$ hence, $i = i_d$.

Thus, $i_c = i_d$ as capacitor gets charged.

7. A photon and a proton have the same de-Broglie wavelength λ . Prove that the energy of the photon is $(2m\lambda c/h)$ times the kinetic energy of the proton. [2]

Answer :

$$\lambda_{pr} = \frac{h}{m_p v} \text{ de-Broglie wavelength of proton}$$

$$\lambda_{ph} = \frac{hc}{E}, \quad (\because E_{ph} = \frac{hc}{\lambda})$$

(de-Broglie wavelength of photon)

$$KE_{\text{proton}} = \frac{1}{2} m_p v^2$$

$$\Rightarrow \lambda_{pr} = \lambda_{ph}$$

Hence,
$$\frac{hc}{E} = \frac{h}{m_p v}$$

$$v = \frac{h}{m_p} \cdot \frac{E}{hc} = \frac{E}{m_p c}$$

$$K.E. = \frac{1}{2} \cdot \frac{E}{m_p c} \cdot \frac{E}{m_p c} m_p$$

$$= \frac{1}{2} \cdot \frac{E \cdot E}{m_p c \cdot c}$$

$$= \frac{1}{2} \cdot \frac{E}{m_p} \cdot \frac{hc}{\lambda c}$$

$$K.E. = \frac{1}{2} \frac{E}{m_p} \cdot \frac{h}{c\lambda}$$

$$K.E. \left(\frac{2m_p c \lambda}{h} \right) = E$$

$$K.E. \left(\frac{2mc\lambda}{h} \right) = E$$

8. A photon emitted during the de-excitation of electron from a state n the first excited state in a hydrogen atom, irradiates a metallic cathode of work function 2 eV , in a photo cell, with a stopping potential of 0.55 V . Obtain the value of the quantum number of the state n . [2]

OR

A hydrogen atom in the ground state is excited by an electron beam 12.5 eV energy. Find out the maximum number of lines emitted by atom from its excited state.

Answer :
$$E_n = 13.6 \left[\frac{1}{1^2} - \frac{1}{n^2} \right] \text{ eV}$$

Work function = 2 eV

\therefore Maximum kinetic Energy

$$= 13.6 \left[\frac{1}{4} - \frac{1}{n^2} \right] - 2 \text{ eV}$$

$$= 0.55 \text{ eV}$$

$$\therefore \frac{13.6}{4} - \frac{13.6}{n^2} - 2 = 0.55$$

$$\frac{13.6}{4} - 2 - 0.55 = \frac{13.6}{n^2} = 0.85$$

$$n^2 = \frac{13.6}{0.85} = 16,$$

$$n = 4$$

OR

Given : $\Delta E = 12.5 \text{ eV}$

Let the electron jump from $n = 1$ to $n = n$ level.

$$\Delta E = E_n - E_1$$

$$\therefore 12.5 = -\frac{13.6}{n^2} - \left(\frac{-13.6}{1^2} \right)$$

$$12.5 = 13.6 \left(1 - \frac{1}{n^2} \right)$$

$$1 - \frac{12.5}{13.6} = \frac{1}{n^2}$$

$$\frac{1.1}{13.6} = \frac{1}{n^2}$$

$$\frac{13.6}{1.1} = n^2$$

$$12.36 = n^2$$

$$n = 3.5$$

$$n = 3^{\text{rd}}$$

Maximum number of lines = 3

9. Draw the ray diagram of an astronomical telescope showing image formation in the normal adjustment position. Write the expression for its magnifying power. [2]

OR

Draw a labelled ray diagram to show image formation by a compound microscope and write the expression for its resolving power.

Answer :

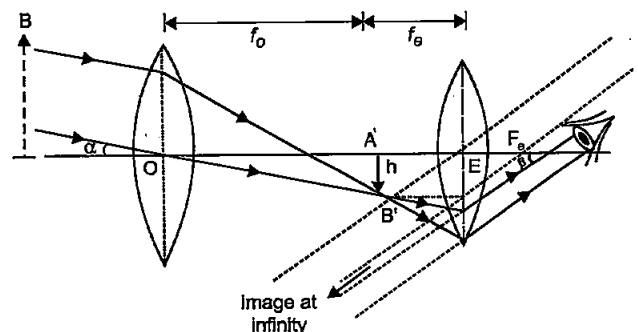

The magnifying power m is the ratio of the angle β subtended at the eye by the final image to the angle α which the object subtends at the lens or the eye. Hence,

$$m = \frac{\beta}{\alpha} = \frac{h}{f_e} \cdot \frac{f_o}{h} = \frac{f_o}{f_e}$$

OR

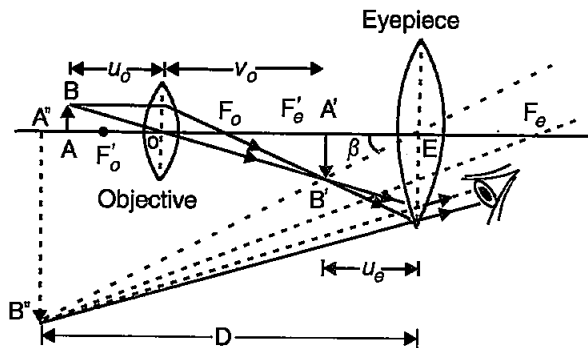

The resolving power of microscope is the reciprocal of the minimum distance.

Therefore, we have

$$R.P. = \frac{1}{d_{min}} = \frac{2n \sin \beta}{1.22 \lambda}$$

10. Write the relation between the height of a TV antenna and the maximum range up to which signals transmitted by the antenna can be received. How is this expression modified in the case of line of sight communication by space waves? In which range of frequencies, is this mode of communication used? [2]
11. Under which conditions can a rainbow be observed? Distinguish between a primary and a secondary rainbow. [2]

Answer : The rainbow is an example of the dispersion of sunlight by the water drops in the atmosphere. This is a phenomenon due to combined effect of dispersion, refraction and reflection of Sunlight by spherical water droplets of rain. The conditions for observing a rainbow are that the Sun should be shining in one part of the sky (say near western horizon) while it is raining in the opposite part of the sky (say eastern horizon).

Difference between Primary and Secondary Rainbow :

S.N.	Primary Rainbow	Secondary Rainbow
1	Three Step process (Refraction-Reflection and Refraction).	Four Step process (Refraction-Reflection and Refraction)
2.	Appearance intensity better than Secondary.	Appearance intensity lesser than Primary.
3.	Single reflection occurs.	Double reflection occurs.
4.	2 Degree range occurs.	3 Degree range.
5.	Fig.1	Fig.2

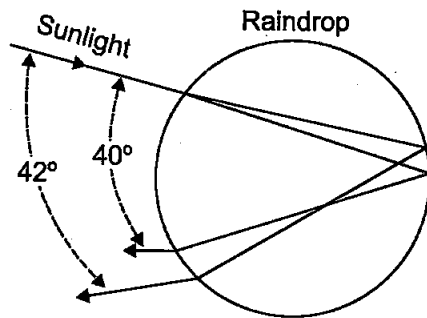

Fig. (1)

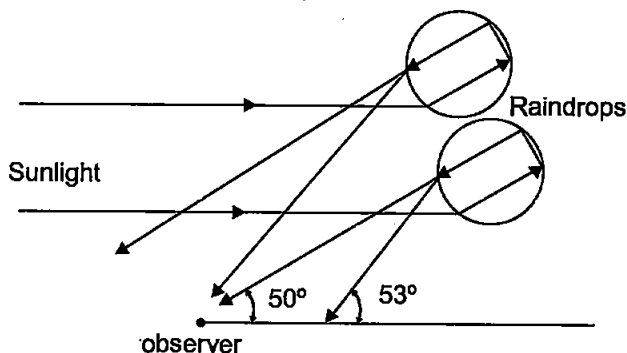

Fig. (2)

12. Explain the following : [2]
- (a) Sky appears blue.
- (b) The Sun appears reddish at (i) sunset, (ii) sunrise.

Answer :

(a) Light from the sun reaches the atmosphere that is comprised of the tiny particles of the atmosphere. These act as a prism and cause the different components to scatter. As blue light travels in shorter and smaller waves in comparison to the other colours of spectrum. It is scattered the most, causing the sky to appear bluish.

(b) The molecules of the atmosphere and other particles that are smaller than the longest wavelength of visible light are more effective in scattering light of shorter wavelengths than light of longer wavelengths. The amount of scattering is inversely proportional to the fourth power of the wavelength. (Rayleigh Effect) Light from the Sun near the horizon passes through a greater distance in the Earth's atmosphere than does the light received when the Sun is overhead. The correspondingly greater scattering of short wavelengths accounts for the reddish appearance of the Sun at rising and at setting.

SECTION-C

13. A capacitor (C) and resistor (R) are connected in series with an ac source of voltage of frequency 50 Hz. The potential difference across C and R

are respectively 120 V, 90 V, and the current in the circuit is 3 A. Calculate (i) the impedance of the circuit (ii) the value of the inductance, which when connected in series with C and R will make the power factor of the circuit unity. [3]

OR

The figure shows a series LCR circuit connected to a variable frequency 230 V source.

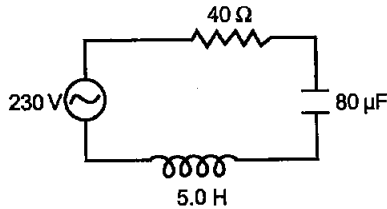

- Determine the source frequency which drives the circuit in resonance.
- Calculate the impedance of the circuit and amplitude of current at resonance.
- Show that potential drop across LC combination is zero at resonating frequency.

Answer :

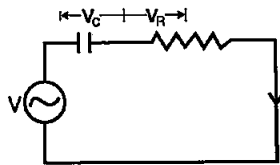

Given,

$$V_c = 120 \quad V_R = 90 \text{ V} \quad I = 3 \text{ A} \quad Z = ?$$

(i) From Kirchhoff's voltage law

$$V = V_c + V_R \\ = 230 \text{ V}$$

$$I = \frac{V}{Z}$$

$$Z = \frac{V}{I} = 230/3 = 76.67 \Omega$$

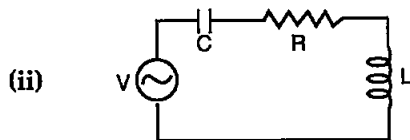

$$\cos \phi = \frac{R}{Z} = 1$$

$$R = Z = R + j \left(\omega L - \frac{1}{\omega C} \right)$$

Hence, $L = \frac{1}{C}$

OR

(a) Source frequency will be same as resonance frequency of LC circuit,

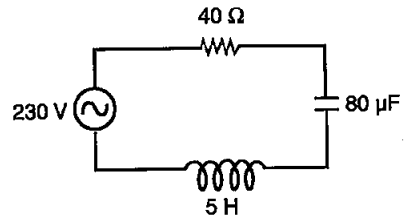

$$f_R = \frac{1}{2\pi\sqrt{LC}} \\ = \frac{1}{2\pi\sqrt{5 \times 80 \times 10^{-6}}} \\ = \frac{1}{2\pi\sqrt{400 \times 10^{-6}}} \\ = \frac{1}{2\pi \times 2 \times 10^{-2}} \\ = \frac{100}{4\pi}$$

$$= 7.957 \text{ Hz} \quad (\because \omega = 2\pi f)$$

$$\omega_r = 50 \text{ Hz}$$

(b) Impedance of circuit

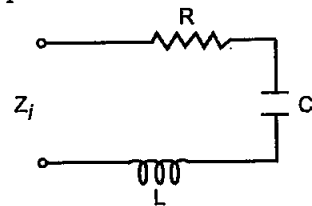

$$z_i = R + j\omega L + \frac{1}{j\omega C} \\ = 40 + 50j \times 5 + \frac{1}{j \times 50 \times 80 \times 10^{-6}} \\ = 40 + 250j + \frac{10^3}{4j}$$

$$z_i = 40 + 250j - 250j \text{ (at resonance)}$$

$$z_i = 40 \Omega$$

Amplitude of current,

$$I = \frac{230}{z_i} \\ = 230/40 = 5.75 \text{ A}$$

(c) As at resonance frequency impedance of combination of L and C is 0.

Hence, voltage drop across LC combination is zero at resonating frequency.

14. Give reason to explain why n and p regions of a Zener diode are heavily doped. Find the current through the Zener diode in the circuit given below : [3]

(Zener breakdown voltage is 15 V)

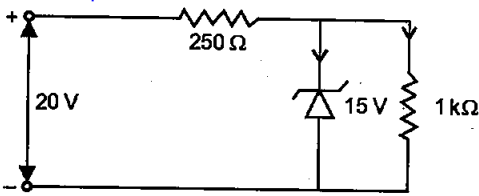

Answer : By heavily doping both *p* and *n* sides of the junction, depletion region formed is very thin, i.e., $< 10^{-6}$ m. Hence, electric field across the junction is very high ($\sim 5 \times 10^6$ V/m) even for a small reverse bias voltage. This can lead to a break down during reverse biasing.

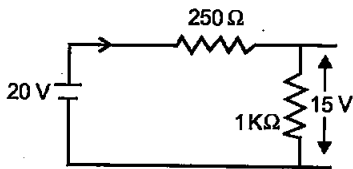
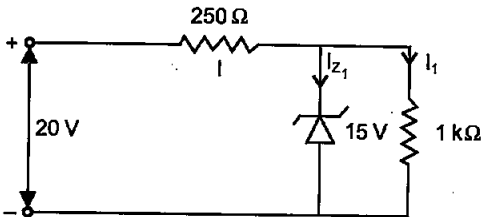

$$I = I_z + I_1$$

$$I_1 = \frac{15}{1} \times 10^{-3} = 1500 \text{A}$$

$$I = \frac{20 - 15}{250} = \frac{5}{250}$$

$$= 20 \text{ mA}$$

Hence,

$$I_z = 20 - 15 \text{ mA}$$

$$= 5 \text{ mA}$$

15. Draw a labelled diagram of cyclotron. Explain its working principle. Show that cyclotron frequency is independent of the speed and radius of the orbit. [3]

OR

- (a) Derive, with the help of a diagram, the expression for the magnetic field inside a very long solenoid having *n* turns per unit length carrying a current *I*.
 (b) How is a toroid different from a solenoid?

Answer :

Cyclotron : Cyclotron is a device by which the positively charged particles like protons, deuterons, etc. can be accelerated.

Principle : Cyclotron works on the principle that a positively charged particle can be accelerated by making it to cross the same electric field repeatedly with the help of a magnetic field.

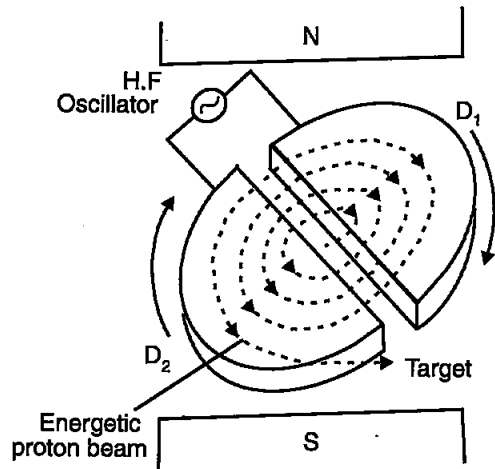

Construction : The construction of a simple cyclotron is shown in figure above. it consist of two semi cylindrical boxes *D*₁ and *D*₂, which are called Dees They are enclosed in an evacuated chamber.

Chamber is kept between the poles of a powerful magnet so that uniform magnetic field acts perpendicular to the plane of the dees. An alternating voltage is applied in the gap between the two dees by the help of a high frequency oscillator. The electric field is zero inside the dees.

Working and theory : At a certain instant, let *D*₁ be positive and *D*₂ be negative. A proton from an ion source will be accelerated towards *D*₂, it describes a semi-circular path with a constant speed and is acted upon only by the magnetic field. The radius of the circular path is given by.

$$qvB = \frac{mv^2}{r}$$

From the above equation we get,

$$r = \frac{mv}{qB} \quad \dots(i)$$

The period of revolution is given by.

$$T = \frac{2\pi r}{v} = \frac{2\pi}{v} \cdot \frac{mv}{qB}$$

$$T = \frac{2\pi m}{qB}$$

The frequency of revolution is given by,

$$f = \frac{1}{T} = \frac{qB}{2\pi m}$$

From the above equation it follows that frequency *f* is independent of both *v* and *r* and is called cyclotron frequency. Also if we make the frequency of applied a.c. equal to *f*, then every time the proton reaches the gap between the dees, the direction of electric field is reversed and proton receives a push and finally it gains very high kinetic energy. The proton follows a spiral path and finally gets

directed towards the target and comes out from it.

OR

(a) Magnetic field inside the solenoid

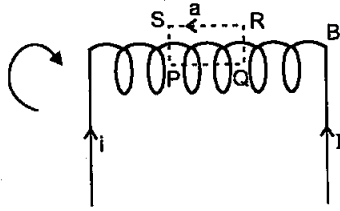

$$\oint \vec{B} \cdot d\vec{l} = \mu_0 I_0 = \mu_0 naI \quad \dots(i)$$

$$\begin{aligned} \oint \vec{B} \cdot d\vec{l} &= \oint_{\text{na}} \vec{B} \cdot d\vec{l} + \oint_{\text{cb}} \vec{B} \cdot d\vec{l} + \oint_{\text{rs}} \vec{B} \cdot d\vec{l} + \oint_{\text{ps}} \vec{B} \cdot d\vec{l} \\ &= B\phi dl \cos 0^\circ + \phi B \cdot dl \cos 90^\circ + 0 \cdot dl \cos 0^\circ + \phi B \cdot dl \cos 90^\circ \\ &= B\phi dl = B \cdot a \quad \dots(ii) \end{aligned}$$

From equation (i) and (ii),

$$\Rightarrow B = \mu_0 nI$$

$$\mu_0 I_0 = \mu_0 naI$$

n = No. of turn per unit length.

a = length of the path.

I = current passing through

(b) Toroid is a form in which a conductor is wound around a circular body. In this case we get magnetic field inside the core but poles are absent because circular body don't have ends. Toroid is used in toroidal inductor, toroidal transformer.

Solenoid is a form in which conductor is wound around a cylindrical body with limb. In this case magnetic field creates two poles N and S. Solenoids have some flux leakage. This is used in relay, motors, electro-magnetes.

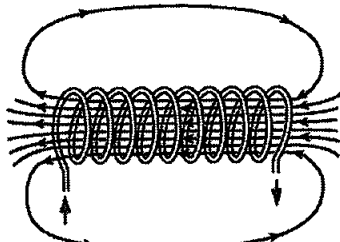

Solenoid Coil

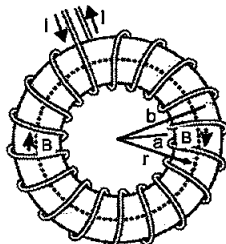

Toroidal Coil

16. Prove that the magnetic moment of the electron revolving around a nucleus in an orbit of radius r with orbital speed v is equal to $evr/2$. Hence using Bohr's postulate of quantization of angular momentum, deduce the expression for the magnetic moment of hydrogen atom in the ground state. [3]

Answer :

$$\mu = - \left(\frac{e}{2m} \right) L$$

where, (-) indicates μ direction is opposite to L .

As Bohr's atomic model

$$L = mvr$$

$$\therefore \mu = - \left(\frac{e}{2m} \right) \times mvr$$

$$\mu = \frac{evr}{2}$$

But from Bohr's second postulate

$$m_e v_r = \frac{nh}{2\pi} \cdot \frac{h}{2\pi r} \quad \text{for } (n = 1)$$

$$v_r = \frac{nh}{2\pi m_e r}$$

Hence the magnetic moment is

$$m = \frac{e}{2} \cdot \frac{h}{2\pi m_e} \quad (\text{Here } n = 1)$$

$$m = \frac{eh}{4\pi m_e}$$

17. Two large charged plane sheets of charge densities σ and $-\sigma$ C/m² are arranged vertically with a separation of d between them. Deduce expressions for the electric field at points (i) to the left of the first sheet, (ii) to the right of the second sheet, and (iii) between the two sheets. [3]

OR

A spherical conducting shell of inner radius r_1 and outer radius r_2 has a charge Q .

(a) A charge q is placed at the centre of the shell. Find out the surface charge density on the inner and outer surfaces of the shell.

(b) Is the electric field inside a cavity (with no charge) zero; independent of the fact whether the shell is spherical or not? Explain. No OTP No Login No Adversitement

Answer :

(i) Electric field due to plane sheet toward

$$\text{right} = \frac{\sigma}{\epsilon_0}$$

Where, σ is charge density.

$$\text{towards left} = \frac{-\sigma}{\epsilon_0}$$

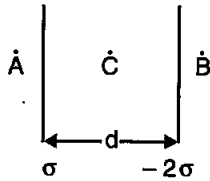

Electric field at point A i.e., to the left of first sheet and due to large plane sheet.

$$\vec{E}_A = -\frac{\sigma}{\epsilon_0} + \left(+\frac{2\sigma}{\epsilon_0} \right) = \frac{\sigma}{\epsilon_0}$$

(ii) Electric field at point B i.e., to the right of second sheet,

$$\vec{E}_B = \frac{\sigma}{\epsilon_0} - \frac{2\sigma}{\epsilon_0} = \frac{-\sigma}{\epsilon_0}$$

(iii) Electric field at point C i.e., between two plates,

$$\vec{E}_C = \frac{\sigma}{\epsilon_0} + \frac{2\sigma}{\epsilon_0} = \frac{3\sigma}{\epsilon_0}$$

OR

(a) Charge on inner surface will be $-q$ and charge on outer surface will be q .

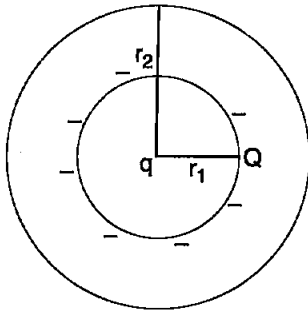

Electric field inside conductor will be zero.

$$\oint \vec{E} \cdot d\vec{a} = 0 = \frac{q}{\epsilon_0} + \frac{q}{\epsilon_0} = 0$$

$q' = -q$ inner surface is equal to zero.

As total charge on spherical shell is Q

Hence, $Q = q_{\text{inner}} + q_{\text{outer}}$

$q_{\text{inner}} = -q$ From Gauss's law

$$q_{\text{outer}} = Q = q$$

Hence, inner surface charge density $\frac{-q}{4\pi r_1^2}$

and outer $\frac{Q+q}{4\pi r_2^2}$

(b) Electric field inside a cavity with no charge will be zero as from Gauss's law

$$\phi_E = \frac{q_{\text{enclosed}}}{\epsilon_0}$$

as $q_{\text{enclosed}} = 0$. Thus ϕ_E will also be zero. electric field will also be zero.

18. A signal of low frequency f_m is to be transmitted using a carrier wave of frequency f_c . Derive the expression for the amplitude modulated wave and deduce expression for the lower and upper sidebands produced. Hence, obtain the expression for modulation index.** [3]

19. Draw a plot of α -particle scattering by a thin foil of gold to show the variation of the number of the scattered particles with scattering angle. Describe briefly how the large angle scattering explains the existence of the nucleus inside the atom, Explain with the help of impact parameter picture, how Rutherford scattering serves a powerful way to determine an upper limit on the size of the nucleus. [3]

Answer :

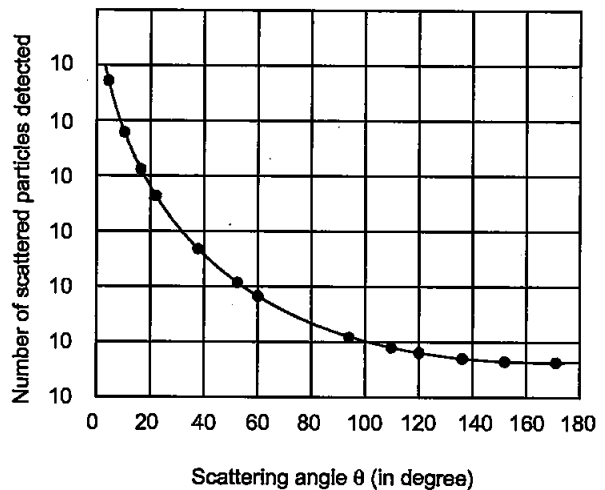

From the plot it is clear that Most of the α -particles passed through the foil, only 0.14% of the incident α particles scatter by more than 1° and about 1 in 8000 deflect by more than 90° α -particles deflected backward due to strong repulsive force. This force will come from positive charge concentrated at the centre as most of the particles get deflected by small angles.

The α -particles trajectory depends on collision's impact parameter (b) for a given beam of α -particles, distribution of impact parameters

as beam gets scattered in different directions with different probabilities.

fig.2 shows α -particle close to nucleus suffers large scattering.

Impact parameter is minimum for head on collision α -particles rebound by 180° .

Impact parameter is high, for undeviated α -particles.

With deflection angle $\cong 0^\circ$.

As these of nucleus was 10^{-14} m to 10^{-15} m w.r.t. 10^{-10} m size of an atom which is 10,000 to 100,000 times larger hence most of the space is empty, only small % of the incident particles rebound back indicates that number of α -particle goes head on collision. Hence most of the mass of the atom is concentrated in small volume.

Thus, Rutherford scattering is a strong tool to determine upper limit to the size of the nucleus.

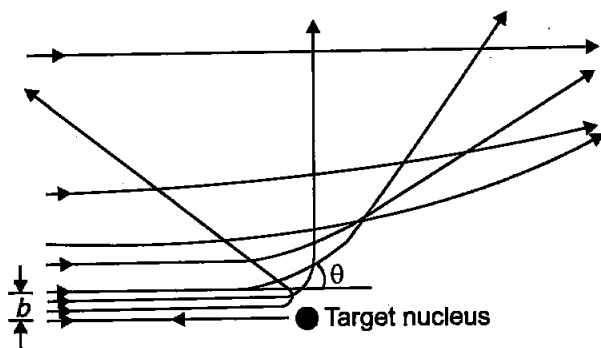

Fig. 2

20. A $200 \mu\text{F}$ parallel plate capacitor having plate separation of 5 mm is charged by a 100 V dc source. It remains connected to the source. Using an insulated handle, the distance between the plates is doubled and a dielectric slab of thickness 5 mm and dielectric constant 10 is introduced between the plates. Explain with reason, how the (i) capacitance, (ii) electric field between the plates, (iii) energy density of the capacitor will change? [3]

Answer : Given, $C = 200 \times 10^{-6} \text{ F}$,

$$d = 5 \text{ mm} = 5 \times 10^{-3} \text{ m}$$

$$Q = CV = 200 \times 10^{-6} \times 100$$

$$= 2 \times 10^{-2} \text{ coulomb.}$$

$$\epsilon_0 A = Cd = 200 \times 10^{-6} \times 5 \times 10^{-3} = 10^{-6}$$

$$A = 10^{-6} / \epsilon_0$$

As dielectric of 5 mm is inserted with spacing between the dielectric doubled then it will act as following-Fig.A and Fig-B.

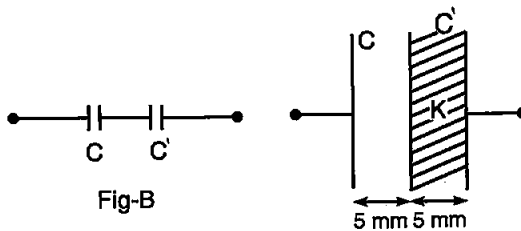

Fig-B

Fig-A

- (i) Here, C' will be the capacitance with dielectric of 5 mm dielectric with 5 mm separation between plates.

$$C' = KC = 10 \times 200 \times 10^{-6} = 2 \times 10^{-3} \text{ F}$$

Thus, equivalent capacitance will be

$$\frac{1}{C_{eq}} = \frac{1}{C} + \frac{1}{C'}$$

$$= \frac{1}{200 \times 10^{-6}} + \frac{1}{2 \times 10^{-3}}$$

$$= \frac{10^3}{2} + \frac{10^3}{2}$$

$$= 5 \times 10^3 + 0.5 \times 10^3$$

$$\frac{1}{C_{eq}} = 5.5 \times 10^3$$

$$C_{eq} = \frac{1}{5.5 \times 10^3}$$

$$= \frac{1}{5.5} \times 10^{-3} = 0.181 \times 10^{-3}$$

$$= 1.81 \times 10^{-4} \text{ F}$$

- (ii) Electric field inside - dielectric will be

$$E' = \frac{E}{K}$$

$$= \frac{100}{5.5 \times 10^{-3} \times 10}$$

$$= 18182 \text{ V/m}$$

Electric field remains same, other than dielectric area,

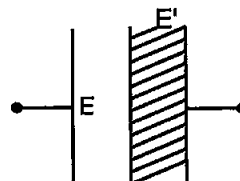

(iii) $U = \frac{Q^2}{2C}$

$$U'' = U' + U$$

$$= \frac{1}{2} \cdot \frac{Q^2}{C} + \frac{1}{2} \cdot \frac{Q^2}{C'}$$

$$= \frac{1}{2} \cdot \frac{Q^2}{C} \left[\frac{1}{C} + \frac{1}{C'} \right]$$

$$= \frac{1}{2} \times 2 \times 10^{-2} \left[\frac{1}{0.2 \times 10^{-3}} + \frac{1}{2 \times 10^{-3}} \right]$$

$$\left[\because \frac{1}{C} + \frac{1}{C'} = \frac{1}{C_{eq}} \right]$$

$$= \left[\frac{1000}{0.2} + \frac{1000}{2} \right]$$

$$= 10^{-2} \times 5.5 \times 10^3 \times 2 \times 10^{-2}$$

$$U'' = 1.1 \text{ J}$$

21. Why is it difficult to detect the presence of an anti-neutrino during β -decay? Define the term decay constant of a radioactive nucleus and derive the expression for its mean life in terms of the decay constant. [3]

OR

- (a) State two distinguishing features of nuclear force.
- (b) Draw a plot showing the variation of potential energy of a pair of nucleons as a function of their separation. Mark the regions on the graph where the force is (i) attractive, and (ii) repulsive.

Answer : The symbols $\bar{\nu}$ and ν present antineutrino and neutrino respectively during β decay : both are neutral particles. With very little or no mass. These particles are emitted from the nucleus along with the electron or positron during the decay process. Neutrinos interact very weakly with matter, they can even penetrate the earth without being absorbed. It is for this reason that their detection is extremely difficult and their presence went unnoticed for long.

Decay constant: Decay constant of a radioactive element is the reciprocal of time during which the number of atoms left in the sample reduces to $\frac{1}{2}$ times the number of atoms in the original sample.

Derivation of mean life :

Let us consider, N_0 be the total number of radioactive atoms present initially. After time t , total no. of atoms present (undecayed) be N . In further dt time dN be the no. of atoms disintegrated. So, the life of dN atoms ranges lies between $t + dt$ and t . Since, dt is very small time, the most appropriate life of dN atom is t . So the total life of N atom = $t \cdot dN$

$$\text{sum of ages of all atoms} = \int_0^{N_0} t dN \quad \dots(i)$$

$$N = N_0 e^{-\lambda t}$$

$$dN = N_0 (-\lambda) e^{-\lambda t} dt$$

Now, substituting the value of dN and changing the limit in equation (i) from (ii) we get

$$= \int_0^{N_0} t N_0 (-\lambda) e^{-\lambda t} dt$$

$$= -\int_0^{N_0} t N_0 (-\lambda) e^{-\lambda t} dt$$

$$= N_0 \lambda \int_0^{N_0} t e^{-\lambda t} dt$$

= sum of life of all atoms

$$\text{Mean life } (\tau) = \frac{N_0 \lambda \int_0^{N_0} t e^{-\lambda t} dt}{N_0}$$

$$\tau = \lambda \int_0^{\infty} t e^{-\lambda t} dt$$

$$\tau = \lambda \times \frac{1}{\lambda^2}$$

$$\tau = \frac{1}{\lambda}$$

This expression gives the relation between mean life and decay constant. Hence, mean life is reciprocal of decay constant.

OR

- (a) Distinguish features of nuclear force are :
- (i) Nuclear forces are very strong binding forces (attractive force.)
 - (ii) It is independent of the charges protons and neutrons (charge independent.)
 - (iii) It depends on the spins of the nucleons.
- (b) Plot showing variation of potential energy of a pair of nucleons as a function of separation mark attractive and repulsive region.

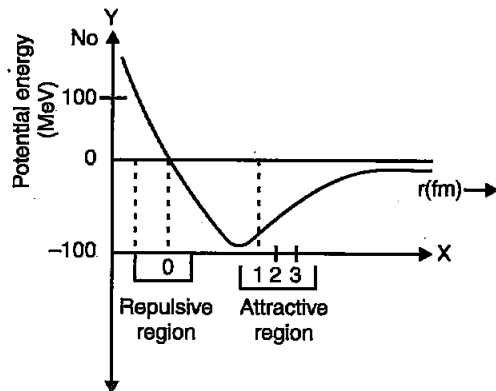

X-axis shows separation between pair of nucleons and Y-axis shows variation of potential energy w.r.t. separation (in $\times 10^{-15}$ m).

22. A triangular prism of refracting angle 60° is made of a transparent material of refractive index $2/\sqrt{3}$. A ray of light is incident normally on the face KL as shown in the figure. Trace the path of the ray as it passes through the prism and calculate the angle of emergence and angle of deviation.

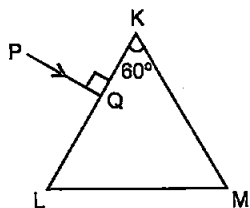

Answer : From diagram it is clear that incidence angle at face KM is 60° .

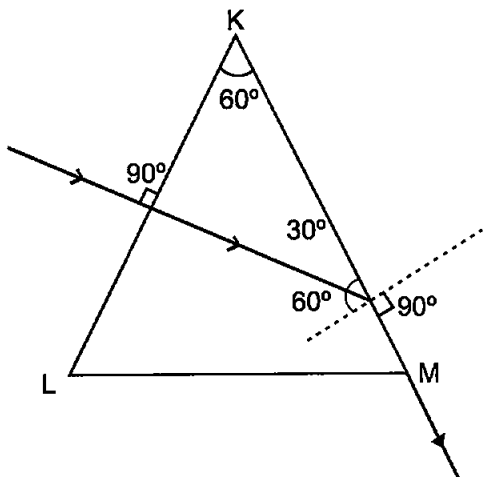

$$\sin C = \frac{1}{\mu} = \frac{\sqrt{3}}{2}$$

Hence, critical angle is also 60° .

Therefore, incident light ray will not emerge from KM face due to total internal reflection at this face. Hence, it will move along face KM. Angle of emergence = 90° .

Hence angle of deviation = 30° (from fig.)

23. Prove that in a common-emitter amplifier, the output and input differ in phase by 180° . In a transistor, the change of base current by $30 \mu\text{A}$ produces change of 0.02 V in the base-emitter voltage and a change of 4 mA in the collector current. Calculate the current amplification factor and the load resistance used, if the voltage gain of the amplifier is 400.** [3]
24. Show, on a plot, variation of resistivity of (i) a conductor, and (ii) a typical semiconductor as a function of temperature.

Using the expression for the resistivity in terms of number density and relaxation time between the collisions, explain how resistivity in the case of a conductor increases while it decreases in a semiconductor, with the rise of temperature. [3]

Answer :

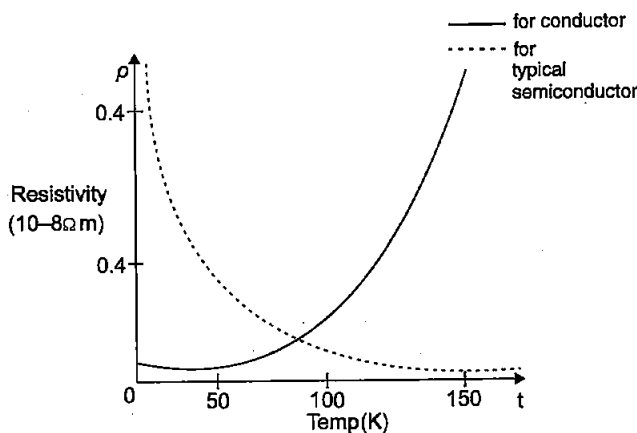

$$\rho = \frac{1}{\sigma} = \frac{m}{ne^2\tau}$$

$n \rightarrow$ number of free electrons

$\tau \rightarrow$ Average time between collisions.

In metals n is not dependent on temperature to any appreciable extent and thus the decrease in the value of τ with rise in temperature causes ρ to increase.

for semiconductors, n increases with temperature. This increases more than compensates any decrease in t , so that for such materials, ρ decreases with temperature.

SECTION D

25. (a) Derive an expression for the induced emf developed when a coil of N turns, and area of cross-section A , is rotated at a constant angular speed ω in a uniform magnetic field B .
- (b) A wheel with 100 metallic spokes each 0.5 m long is rotated with a speed of 120 rev/min in a plane normal to the horizontal component of the Earth's magnetic field. If the resultant magnetic field at that place is $4 \times 10^{-4} \text{ T}$ and the angle of dip at the place is 30° , find the emf induced between the axle and the rim of the wheel. [5]

OR

- (a) Derive the expression for the magnetic energy stored in an inductor when a current I develops in it. Hence, obtain the expression for the magnetic energy density.
- (b) A square loop of sides 5 cm carrying a current of 0.2 A in the clockwise direction is placed at a distance of 10 cm from an infinitely long wire carrying a current of 1 A as shown. Calculate (i) the resultant magnetic force, and (ii) the torque, if any, active on the loop.

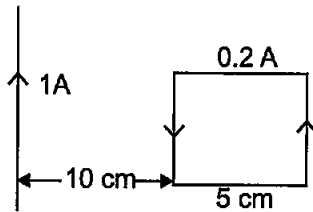

Answer :

(a) As the armature coil is rotated in the magnetic field, angle θ between the field and normal to the coil changes continuously. Therefore, magnetic flux linked with the coil changes. An e.m.f. is induced in the coil. According to Fleming's right hand rule, current induced in AB is from A to B and it is from C to D in CD in the external circuit current flows from B_2 to B_1 .

To calculate the magnitude of e.m.f. induced :

Suppose,

A \rightarrow Area of each turn of the coil

N \rightarrow Number of turns in the coil

B \rightarrow Strength of magnetic field

$\theta \rightarrow$ Angle which normal to the coil makes with \vec{B} at any instant t

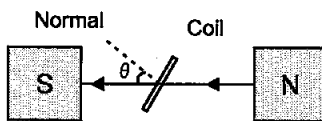

\therefore Magnetic flux linked with the coil in this position.

$$\phi = N(\vec{B} \cdot \vec{A}) = NBA \cos \theta = NBA \cos \omega t \dots(i)$$

Where, ω is angular velocity of the coil

As the coil rotates, angle θ changes. Therefore, magnetic flux ϕ linked with the coil changes and hence, an e.m.f. is induced in the coil. At this instant t , if e is the e.m.f. induced in the coil, then

$$e = - \frac{d\phi}{dt} = - \frac{d}{dt} (NAB \cos \omega t)$$

$$= - NAB \frac{d}{dt} (\cos \omega t)$$

$$= - NAB (-\sin \omega t) \omega$$

$$\therefore e = NAB \omega \sin \omega t$$

$$e = \epsilon_0 \sin \omega t \text{ (Here } \epsilon_0 = NBA\omega \text{)}$$

(b) We have number spokes (N) = 100

Length of each spoke (L) = 0.5 m

Magnetic field (B) = $0.4 \times 10^{-4} \text{ T} = 4 \times 10^{-5} \text{ T}$

Frequency (f) = 120 rpm = 2 rps

induced e.m.f. between axle and rim is given by

$$\begin{aligned} e &= N \times B \times l^2 \times \pi \times f \\ &= 100 \times 4 \times 10^{-5} \times (0.5)^2 \times 3.14 \times 2 \\ &= 6.28 \times 10^{-3} \text{ V} \end{aligned}$$

OR

(a) **Energy stored in an inductor :** When a current flows through an inductor, a back e.m.f. is set up which opposes the growth of current. So, work needs to be done against back e.m.f. (e) in building up the current. This work done is stored as magnetic potential energy.

Let, I be the current through the inductor L at any instant t .

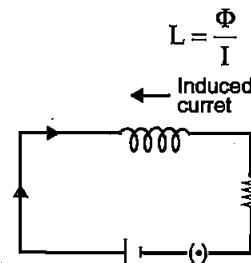

The current rises at the rate $\frac{dI}{dt}$.
So, the induced e.m.f. is :

$$e = \frac{-LdI}{dt}$$

The work done against induced e.m.f. in dt is :

$$\begin{aligned} dW &= PdI \\ &= -eIdt \\ &= \frac{-LdI}{dt} Idt \\ &= LI dI \end{aligned}$$

For total work from 0 to I_0 current,

$$\begin{aligned} W &= \int_0^{I_0} dW \\ &= \int_0^{I_0} LI dI \\ &= L \left[\frac{I^2}{2} \right]_0^{I_0} \\ &= \frac{1}{2} LI_0^2 \end{aligned}$$

Hence, this work done is stored as the magnetic potential energy U in the inductor

$$U = \frac{1}{2} LI^2$$

The magnetic energy is given by

$$U_B = \frac{1}{2} LI^2$$

$$\begin{aligned}
 &= \frac{1}{2}L\left(\frac{B}{\mu_0 n}\right)^2 \quad (\text{since } B = \mu_0 nI) \\
 &= \frac{1}{2}(\mu_0 n^2 Al)\left(\frac{B}{\mu_0 n}\right)^2 \\
 &\quad (\because L = \mu_0 n^2 Al) \\
 &= \frac{1}{2\mu_0} B^2 Al
 \end{aligned}$$

The magnetic energy per unit volume or magnetic energy density is given by,

$$\begin{aligned}
 u_B &= \frac{U_B}{V} \quad (\text{where, } V \text{ is volume that contains flux}) \\
 &= \frac{U_B}{Al} \\
 &= \frac{B^2}{2\mu_0} Al
 \end{aligned}$$

(b)

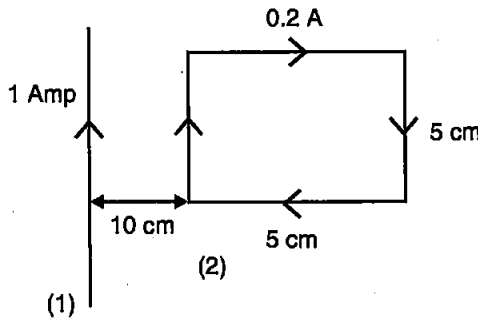

To calculate resultant magnetic force,

$$F = I(\vec{L} \times \vec{B})$$

$$F_{AB} = I_2(\vec{L} \times \vec{B}_1)$$

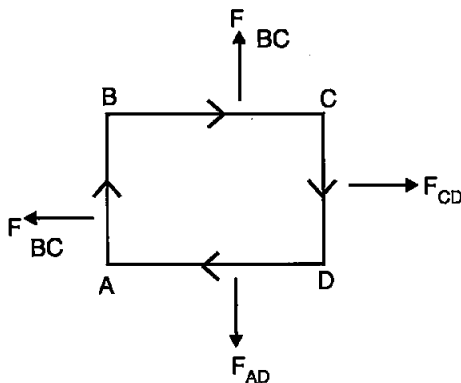

Direction of field B due to current in long wire inward \otimes

$$B = \frac{\mu_0 I_1}{2\pi r}$$

Where, r = distance from long wire

$$\frac{\mu_0}{2\pi r} I_1 I_2 L_{AB} = I_2 \times 5 \times 10^{-2} \times \frac{\mu_0 \times I_1 \sin \theta}{2\pi \times 10 \times 10^{-2}}$$

$$= 0.2 \times 5 \times 10^{-2} \times \frac{\mu_0 \times I}{2\pi \times 10 \times 10^{-2}} \quad (\because \theta = 0^\circ)$$

$$|\vec{F}_{AB}| = \frac{\mu_0}{2\pi} \cdot \frac{1}{10} \quad (\text{in the direction shown in fig})$$

$$|\vec{F}_{CB}| = I_2(\vec{L} \times \vec{B}_1)$$

$$= 0.2 \times 5 \times 10^{-2} \times \frac{\mu_0}{2\pi} \times \frac{1}{15 \times 10^{-2}}$$

$$= \frac{\mu_0}{2\pi} \times \frac{1}{15}$$

$$|\vec{F}_{BC}| = |\vec{F}_{AD}| \quad \because |F_{YNet}| = 0$$

Thus net magnetic force,

$$F_{net} = |\vec{F}_{AB}| - |\vec{F}_{CD}|$$

$$= \frac{\mu_0}{2\pi} \left[\frac{1}{10} - \frac{1}{15} \right]$$

$$= \frac{4\pi \times 10^{-7}}{2\pi} \times [0.0333]$$

$$= 0.067 \times 10^{-7}$$

$$= 67 \times 10^{-10} \text{ N}$$

The forces acting on all sides of the square due to current of infinite length wire are lying in the plane of coil. Thus, there is no net torque. Thus torque is zero.

26. Explain, with the help of a diagram, how plane polarized light can be produced by scattering of light from the Sun.

Two polaroids P_1 and P_2 are placed with their pass axes perpendicular to each other. Unpolarised light of intensity I is incident on P_1 . A third polaroid P_3 is kept between P_1 and P_2 such that its pass axis makes an angle of 45° with that of P_1 . Calculate the intensity of light transmitted P_1 , P_2 and P_3 . [5]

OR

(a) Why cannot the phenomenon of interference be observed by illuminating two pin holes with two sodium lamps?

(b) Two monochromatic waves having displacements $y_1 = a \cos \omega t$ and $y_2 = a \cos(\omega t + \phi)$ from two coherent sources interfere to produce an interference pattern. Derive the expression for the resultant intensity and obtain the conditions for constructive and destructive interference.

(c) Two wavelengths of sodium light of 590 nm and 596 nm are used in turn to study the diffraction taking place at a single slit of aperture 2×10^{-6} m. If the distance between the slit and the screen is 1.5 m, calculate the separation between the positions of the second maxima of diffraction pattern obtained in the two cases.

Answer :

Molecules behave like dipole radiators and scatter no energy along the dipole axis by this way plane polarized light can be produced during scattering of light.

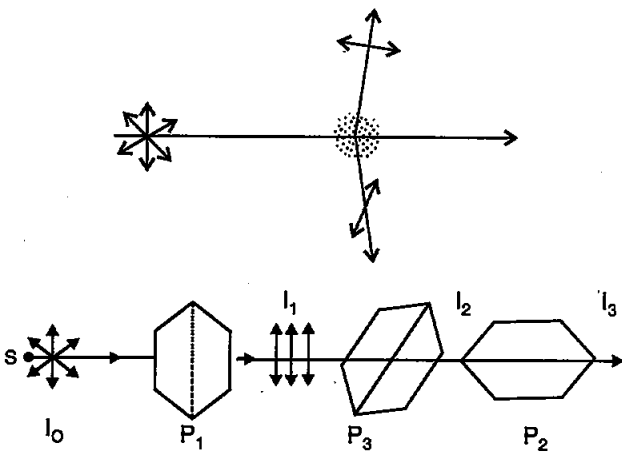

Intensity of light after passing through the polaroid $P_1(I_1)$

$$I_1 = I_0/2$$

Intensity of light after passing through P_3

$$I_2 = I_1 \cos^2 45^\circ$$

$$I_2 = \frac{I_1}{2} = \frac{I}{4}$$

Intensity of light after passing through P_2

$$I_3 = I_2 \cos^2 45^\circ = \frac{I}{4} \times \frac{I}{2} = \frac{I}{8}$$

OR

(a) Phenomenon of interference can't be observed by illuminating two pin holes with two sodium lamps because these sources are not coherent source (it means they are not in same phase).

(b) Consider two monochromatic coherent sources A and B with waves $y_1 = a \cos \omega t$ and $y_2 = b \cos (\omega t + \phi)$ respectively.

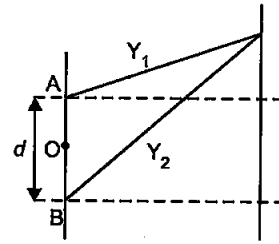

From principle of superposition,

$$\begin{aligned} y &= y_1 + y_2 \\ &= a \sin \omega t + b \sin (\omega t + \phi) \\ &= a \sin \omega t + b \sin \omega t \cos \phi + b \cos \omega t \sin \phi \\ &= (a + b \cos \phi) \sin \omega t + b \sin \phi \cos \omega t \end{aligned}$$

Let,

$$a + b \cos \phi = A \cos \delta$$

$$b \sin \phi = A \sin \delta$$

$$y = A \sin \omega t \cos \delta + A \cos \omega t \sin \delta$$

$$= A \sin (\omega t + \delta)$$

$$A = \sqrt{a^2 + b^2 + 2ab \cos \phi}$$

$$\tan \delta = \frac{b \sin \phi}{a + b \cos \phi}$$

1. constructive interference

For I-maxima,

$$I \propto A^2$$

and for A to be maximum,

$$\cos \phi = 1$$

$$\cos \phi = \cos 2n\pi, n = 0, 1, 2, 3, \dots$$

$$\phi = 2n\pi$$

and path difference,

$$\Delta x = n\lambda$$

$$A_{\max} = a + b$$

$$I \rightarrow I_{\max} = k (a + b)^2$$

2. Destructive Interference

For I - minima

$$\cos \phi = -1$$

$$\Delta \phi = (2n + 1)\pi$$

Path difference,

$$\Delta x = (2n + 1) \lambda/2$$

$$A_{\min} = a - b$$

$$I \rightarrow I_{\min} = k (a - b)^2$$

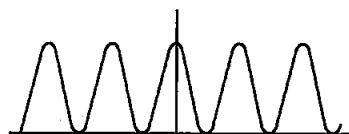

$$(c) \theta = (n + 1/2) \lambda/a$$

$$a = 2 \times 10^{-6} \text{ (aperture of slit)}$$

$$\theta_1 = \frac{\lambda}{2a} = \frac{590 \times 10^{-9}}{4 \times 10^{-6}} = \frac{590}{4} \times 10^{-3}$$

$$= 147.5 \times 10^{-3}$$

$$\theta_1 = \frac{\lambda'}{2a} = \frac{596 \times 10^{-9}}{4 \times 10^{-6}} = 149 \times 10^{-3}$$

$$\theta_2 - \theta_1 = 1.5 \times 10^{-3} \text{ (Angular difference)}$$

$$\lambda_1 = 596 \text{ nm}, \lambda_2 = 590 \text{ nm}$$

$$a = 2 \times 10^{-6}$$

$$D = 1.5 \text{ m}$$

$$y = \frac{3\lambda D}{2a}$$

$$y_1 - y_2 = \frac{3D}{2a} (\lambda_1 - \lambda_2)$$

$$= \frac{3 \times 1.5}{2 \times 2 \times 10^{-6}} (596 - 590) \times 10^{-9} \text{ m}$$

$$= \frac{4.5}{4 \times 10^{-6}} \times 6 \times 10^{-9} \text{ m}$$

$$= \frac{4.5 \times 6}{4} \times 10^{-3} \text{ m}$$

$$= 6.78 \text{ nm}$$

27. (a) Describe briefly, with the help of a circuit diagram, the method of measuring the internal resistance of a cell.
- (b) Give reason why a potentiometer is preferred over a voltmeter for the measurement of emf of a cell.
- (c) In the potentiometer circuit given below, calculate the balancing length l . Give reason, whether the circuit will work, if the driver cell of emf 5 V is replaced with a cell of 2 V, keeping all other factors constant. [5]

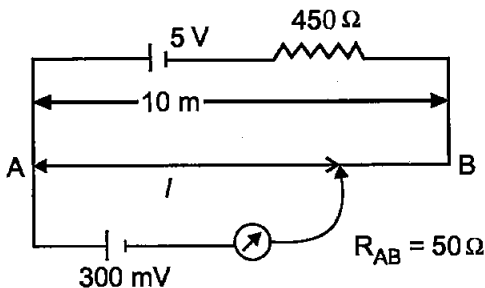

OR

- (a) State the working principle of a meter bridge used to measure an unknown resistance.
- (b) Give reason.
- (i) why the connections between the resistors in a metre bridge are made of thick copper strips.
- (ii) why is it generally preferred to obtain the balance length near the mid-point of the bridge wire.

- (c) Calculate the potential difference across the 4 Ω resistor in the given electrical circuit, using Kirchoff's rules.

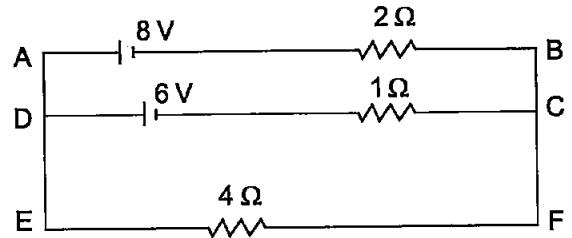

Answer :

- (a) When K_2 is open, balance is obtained at $l_1 = AN_1$
 $\epsilon = \phi l_1$
 when K_2 is closed
 $V = \phi l_2$,

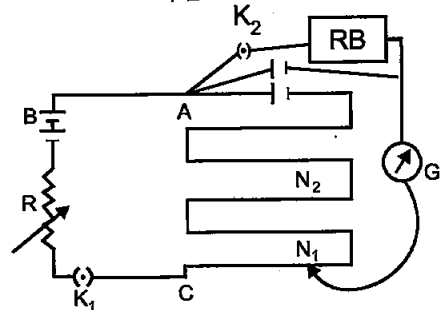

Circuit for determining internal resistance of cell.

$$\frac{\epsilon}{V} = \frac{l_1}{l_2}$$

But,

$$\epsilon = I(r + R) \text{ and } V = IR$$

Thus,

$$\frac{\epsilon}{V} = \frac{r + R}{R} = \frac{l_1}{l_2}$$

$$r = R \left(\frac{l_1}{l_2} - 1 \right)$$

Where, r is the internal resistance of cell.

(b) Potentiometer is preferred over voltmeter for measurement of e.m.f. of cell because a voltmeter draws some current from the cell while potentiometer draws no current.

Therefore, the potentiometer measures the actual e.m.f. of cell whereas voltmeter measures the terminal voltage.

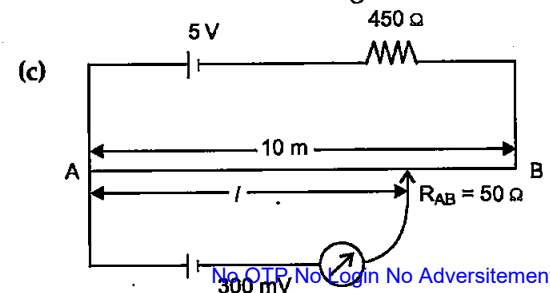

For current through AB,

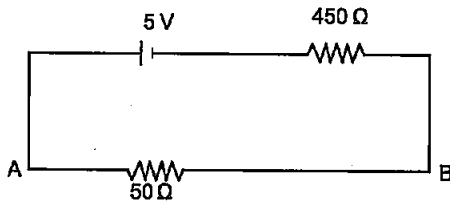

$$I = \frac{V}{R} = \frac{5}{500} = 10 \text{ mA}$$

10 mA current passes through AB. Thus, voltage drop through AB = $V_{AB} = 10 \times 10^{-3} \times 50 = 500 \text{ mV}$

Voltage drop per unit length

$$\text{(volts/m)} = \frac{500 \text{ mV}}{10} = 50 \text{ mV/m}$$

balancing point is at 300 mV

Hence, l will be 6m.

When 5V is replaced with 2V

$$I_{AB} = \frac{2}{500} = 4 \text{ mA}$$

$$V_{AB} = 4 \text{ mA} \times 50 = 200 \text{ mV}$$

Hence, balancing will not possible as it needs to cater 300 mV.

OR

(a) Meter bridge is the practical apparatus which works on principle of Wheat-Stone bridge. It is used to measure unknown resistance experimentally.

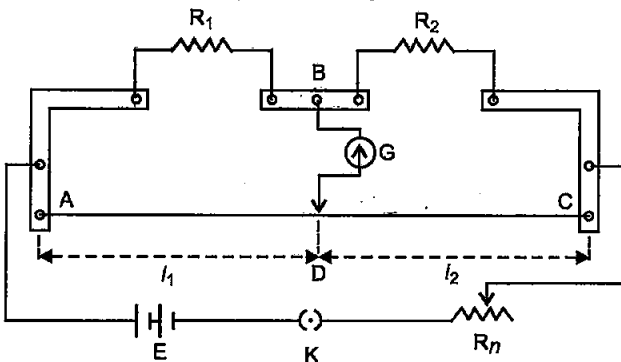

Hence, as per Wheat-Stone bridge balance condition :

$$\frac{R_1}{R_2} = \frac{\text{Resistance of wire AD}}{\text{Resistance of wire DC}}$$

Where, D is point of balance.

$$\frac{R_1}{R_2} = \frac{\rho l_1}{\rho l_2} = \frac{l_1}{l_2} = \frac{l_1}{(100-l_1)}$$

$$(\because l_1 + l_2 = 100 \text{ cm})$$

ρ = resistance per unit length of wire.

$$R_1 = R_2 \frac{l_1}{(100-l_1)}$$

(b) (i) Connection between resistors are made of thick copper strips so that it will have maximum resistance and location of point of balance (D) will be more accurate which results in correct measurement of unknown resistance.

(ii) It is preferred to obtain the balance length near the mid-point of the bridge wire because it increase the sensitivity of meter bridges.

(c) From KCL (Kirchhoff's current lw) at point D

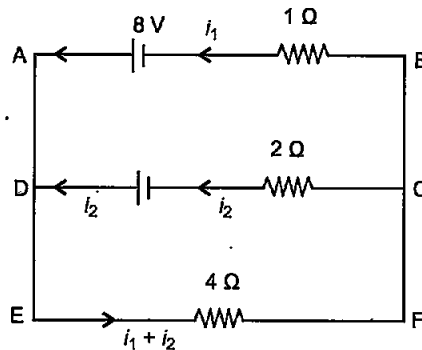

Current flowing through 4Ω resistance

$$i_1 + i_2 = i$$

KVL in loop DEFCD,

$$\Sigma V = 0$$

$$-(i_1 + i_2)4 - i_2 + 6 = 0$$

$$-4i_1 - 5i_2 + 6 = 0$$

(Voltage drop is negative and gain is positive)

$$4i_1 + 5i_2 = 6$$

KVL in loop AEFBA,

$$-(i_1 + i_2)4 - 2i_1 + 8 = 0$$

$$-4i_1 - 4i_2 - 2i_1 + 8 = 0$$

$$-6i_1 - 4i_2 + 8 = 0$$

$$6i_1 + 4i_2 = 8 \quad \dots(i)$$

$$4i_1 + 5i_2 = 6 \quad \dots(ii)$$

Afer solving both (i) and (ii)

$$i_1 = 8/7$$

$$i_2 = 2/7$$

Physics 2019 (Outside Delhi)

SET II

Time allowed : 3 hours

Maximum marks : 70

Note : Except for the following questions, all the remaining questions have been asked in previous set.

- Write the relation for the force acting on a charged particle q moving with velocity \vec{v} in the presence of a magnetic field \vec{B} . [1]

Answer : $\vec{F} = q(\vec{v} \times \vec{B})$

- Draw the pattern of electric field lines due to an electric dipole. [1]

Answer :

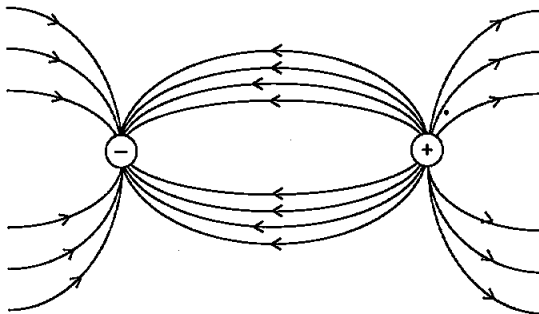

- Identify the semiconductor diode whose I-V characteristics are as shown. [1]

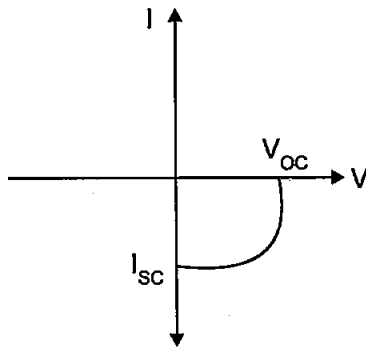

Answer : Photodiode/Solar cell.

SECTION-B

- How is the equation for Ampere's circuital law modified in the presence of displacement current? Explain. [2]

Answer :

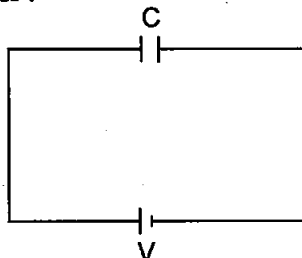

From Ampere's law,

$$\oint \vec{B} \cdot d\vec{l} = \mu_0 i(t)$$

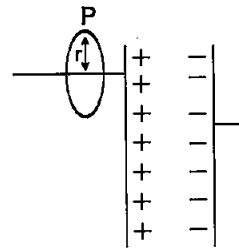

Case-1

Let, the case-1 where a point P is considered outside capacitor charging from Ampere's law.

Magnetic field at point will be

$$B \cdot (2\pi r) = \mu_0 i(t)$$

$$B = \frac{\mu_0}{2\pi r} i(t)$$

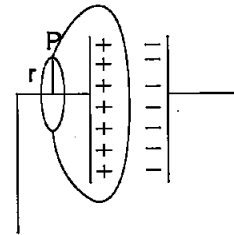

Case-2

Now take case-2 where shape surface under consideration covers capacitor's plate as we consider there is no current through capacitor then this value of B will be zero.

Hence, there is a contradiction.

Therefore this Ampere's law was modified with addition of displacement current inside capacitor.

$$\phi_E = |E| A = \frac{1}{\epsilon_0} \cdot \frac{Q}{A} \cdot A = \frac{Q}{\epsilon_0}$$

$$\frac{d\phi_E}{dt} = \frac{1}{\epsilon_0} \cdot \frac{dQ}{dt}$$

$$\epsilon_0 \frac{d\phi_E}{dt} = \frac{dQ}{dt} = i_d$$

Where, i_d is displacement current.

During charging of capacitor, outside the capacitor, i_c (conduction current) flows and inside i_d displacement current flows.

$$i = i_c + i_d = i_c + \epsilon_0 \frac{d\phi_E}{dt}$$

Outside the capacitor $i_d = 0$ hence, $i = i_c$

and inside the capacitor $i_c = 0$ hence, $i = i_d$

8. Under what conditions does the phenomenon of total internal reflection take place? Draw a ray diagram showing how a ray of light deviates by 90° after passing through a right-angled isosceles prism. [2]

Answer :

The phenomenon of total internal reflection occurs when,

1. Angle of incidence is equal or greater than critical angle.

$$i \geq C$$

2. When light travels from more denser medium to less denser medium.

In case of right angle isosceles triangle if light rays fall normally on AB then light incident of face AC with angle of incidence $>$ critical angle.

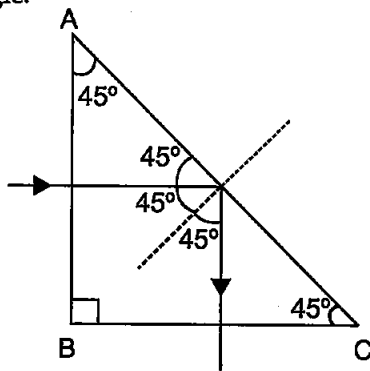

Hence, total internal reflection will occur with normal to the surface of BC.

11. A beam of light converges at a point P. Draw ray diagrams to show where the beam will converge if (i) a convex lens, and (ii) a concave lens is kept in the path of the beam. [2]

Answer : (i)

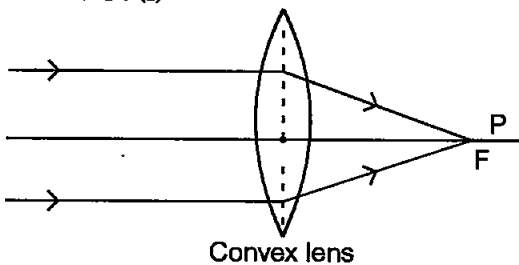

(ii)

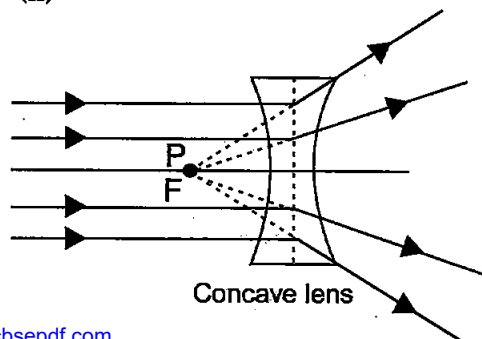

SECTION-C

14. (a) How is the stability of hydrogen atom in Bohr model explained by de-Broglie's hypothesis?

(b) A hydrogen atom initially in the ground state absorbs a photon which excites it to $n = 4$ level. When it gets de-excited, find the maximum number of lines which are emitted by the atom. Identify the series to which these lines belong. Which of them has the shortest wavelength? [3]

Answer :

(a) From Bohr's model-An atom has a number of stable orbits in which an electron can reside without the emission of radiant energy. Each orbit corresponds to a certain energy level.

\therefore Electron revolves in circular orbit

$$\therefore \frac{mv^2}{r} = \frac{e^2}{4\pi\epsilon_0 r^2} \quad \left(\text{Diagram of a circular orbit with radius } r \text{ and momentum } p = mv \right)$$

The motion of an electron in circular orbits is restricted in such a manner that its angular momentum is an integral multiple of $h/2\pi$

$$\text{Thus, } L = mvr = \frac{nh}{2\pi}$$

$$E_n = \frac{-13.6}{r^2} z^2 \text{ eV}$$

$Z = 1$ for H_2 atom

$$E_n = \frac{-13.6}{r^2} \text{ eV}$$

From de-Broglie hypothesis

$$\lambda = \frac{h}{p} = \frac{h}{mv}$$

And from Bohr model

$$n\lambda = 2\pi r$$

$$\lambda = \frac{2\pi r}{n}$$

$$\frac{h}{mv} = \frac{2\pi r}{n}$$

$$\frac{nh}{2\pi} = mvr = L$$

(b) $n_i = 1, n_f = 4.$

Possible transitions are :

$$\Rightarrow 4 \rightarrow 3, 4 \rightarrow 2, 4 \rightarrow 1$$

$$\text{or } 3 \rightarrow 2, 3 \rightarrow 1,$$

$$\text{or } 2 \rightarrow 1$$

Hence, Six lines are possible.

$$\left. \begin{matrix} 4 \rightarrow 1 \\ 3 \rightarrow 1 \\ 2 \rightarrow 1 \end{matrix} \right\} \text{ Lyman series}$$

- $3 \rightarrow 2$
- $4 \rightarrow 2$ } Balmer series
- $4 \rightarrow 3$ Paschen series
- $4 \rightarrow 1$ has smallest wavelength.

16. What is the reason to operate photodiodes in reverse bias?

A *p-n* photodiode is fabricated from a semiconductor with a band gap of range of 2.5 to 2.8 eV. Calculate the range of wavelengths of the radiation which can be detected by the photodiode. [3]

Answer : Photodiode are reverse biased for working in photo-conductive mode. This reduces the response time because the additional reverse bias increases the width of the depletion layer, which decreases the junction capacitance. The reverse bias also increases the dark current without much change in the photo current.

Given, $E = 2.5 - 2.8 \text{ eV}$

$$E = \frac{hc}{\lambda}$$

$$\lambda_1 = \frac{hc}{E_1} = \frac{6.63 \times 10^{-34} \times 3 \times 10^8}{2.5 \times 1.6 \times 10^{-19}} = \frac{3 \times 6.63 \times 10^{-7}}{-2.5 \times 1.6} = 497.25 \text{ nm}$$

$$\lambda_2 = \frac{hc}{E_2} = \frac{6.63 \times 10^{-34} \times 3 \times 10^8}{2.8 \times 1.6 \times 10^{-19}} = 443.97 \text{ nm}$$

The range of wavelengths of radiation which can be detected by the photodiode is 443.97 nm to 497.25 nm.

18. A ray of light incident on the face AB of an isosceles triangular prism makes an angle of incidence (*i*) and deviates by angle β as shown in the figure. Show that in the position of minimum deviation $\angle \beta = \angle \alpha$. Also find out the condition when the refracted ray QR suffers total internal reflection. [3]

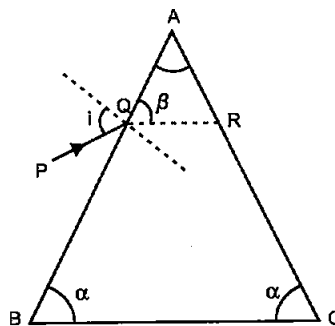

Answer :

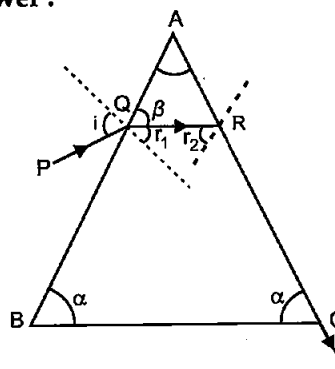

$$\frac{\sin i}{\sin r} = \mu$$

(i) Condition for minimum deviation :

1. $A = 180 - 2\alpha$

2. $\frac{\sin i}{\sin(90 - \beta)} = \mu$

when, $r_1 = r_2 = r > \text{critical angle}$

$$r_1 + r_2 = 180 - 2\alpha$$

$$2r = 180 - 2\alpha \quad [\because r_1 = r_2]$$

$$r_1 = r = 90 - \alpha$$

$$\beta = 90 - r_1 = 90 - 90 + \alpha$$

$$\beta = \alpha$$

condition when QR have total internal reflection :

$$\angle QRC \geq \text{critical angle for the prism}$$

$$\angle 180^\circ - \beta \geq \text{critical angle}$$

or

$$\angle 180^\circ - \alpha \geq \text{critical angle}$$

$$\therefore \angle 180^\circ - \alpha = \angle BAC$$

$$\therefore \angle BAC \geq \text{critical angle}$$

22. A 100 μF parallel plate capacitor having plate separation of 4 mm is charged by 200 V dc. The source is now disconnected. When the distance between the plates is doubled and a dielectric slab of thickness 4 mm and dielectric constant 5 is introduced between the plates, how will (i) its capacitance, (ii) the electric field between the plates, and (iii) energy density of the capacitor get affected? Justify your answer in each case. [3]

Answer : Given,

$$\begin{aligned}
 c &= 100 \mu\text{F} \\
 d &= 4 \times 10^{-3}\text{m.} \\
 V &= 200\text{V} \\
 k &= 5 \\
 Q &= CV \\
 &= 200 \times 100 \times 10^{-6} \\
 &= 2 \times 10^{-2} \text{Coulomb}
 \end{aligned}$$

As dielectric of 4 mm is inserted between the plates of capacitor and the spacing between the plates is doubled then it will acts as following Fig-A and Fig-B.

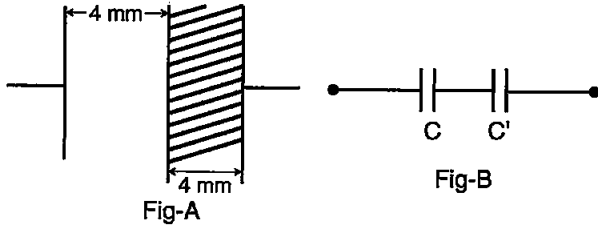

Here, C' will be capacitance with dielectric of 4 mm & 8 mm separation between the plates.
 $C' = KC = 5 \times 100 \times 10^{-6} = 0.5 \times 10^{-3} \text{ F}$

(i) Thus, equivalent capacitance

$$\begin{aligned}
 \frac{1}{C_{eq}} &= \frac{1}{C} + \frac{1}{C'} = \frac{1}{100 \times 10^{-6}} + \frac{1}{0.5 \times 10^{-3}} \\
 &= 10 \times 10^3 + 2 \times 10^3 \\
 &= 12 \times 10^3 \\
 \frac{1}{C_{eq}} &= 12 \times 10^3
 \end{aligned}$$

$$\begin{aligned}
 C_{eq} &= \frac{1}{12 \times 10^3} \\
 &= \frac{1}{12} \times 10^{-3} \\
 C_{eq} &= 83.33 \mu\text{F}
 \end{aligned}$$

(ii) Electric field inside dielectric will be

$$\begin{aligned}
 (E) &= \frac{E}{K} = \frac{50}{5 \times 4 \times 10^{-3}} \\
 &= \frac{50 \times 10^3}{5} = 10 \times 10^3 \\
 &= 1000 \text{ V/m.}
 \end{aligned}$$

and Electric field inside capacitor but out of dielectric Area will be

$$E = 50 \times 10^3 \text{ V/m}$$

(iii) Energy density of capacitor is given by :

$$\begin{aligned}
 U &= \frac{Q^2}{2C} \\
 &= U' + U \\
 &= \frac{Q^2}{2C} + \frac{Q^2}{2C'} \\
 \Rightarrow \frac{Q^2}{2} \left[\frac{1}{C} + \frac{1}{C'} \right] &= \frac{2 \times 10^{-2} \times 2 \times 10^{-2}}{2} [12 \times 10^3] \\
 &= 2 \times 10^{-1} \times 12 \\
 &= 2.4 \text{ J}
 \end{aligned}$$

Physics 2019 (Outside Delhi)

SET III

Time allowed : 3 hours

Maximum marks : 70

Note : Except for the following questions, all the remaining questions have been asked in previous sets.

2. Draw a pattern of electric field lines due to two positive charges placed a distance d apart. [1]

Answer : Electric field lines due to two positive charge placed to at distance d apart :

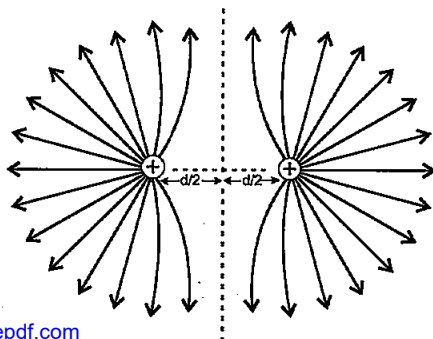

4. When a charge q is moving in the presence of electric (E) and magnetic (B) fields which are perpendicular to each other and also perpendicular to the velocity v of the particle, write the relation expressing v in terms of E and B. [1]

Answer : $v = E/B$

5. Draw the I-V characteristics of a Zener diode. [1]

Answer :

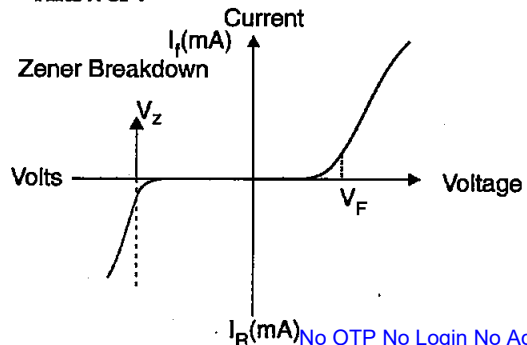

SECTION-B

6. State, with the help of a ray diagram, the working principle of optical fibres. Write one important use of optical fibres. [2]

Answer :

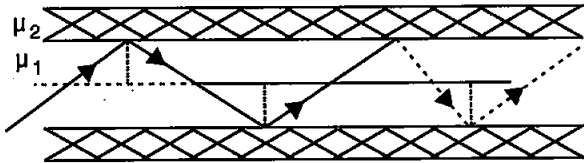

Optical fibre works on principle of total internal reflection. When angle of incidence is greater than Critical angle then incident rays are totally reflected back in same media.

When, $\theta_i > \theta_C$, Total internal reflection occurs and if $\theta_i < \theta_C$, refraction occurs.

Application : Optical fibre are used for communication due to very high bandwidth of media.

8. How are electromagnetic waves produced by oscillating charges? What is the source of the energy associated with the em waves [2]

Answer : Oscillating charges are responsible for generation of periodically varying electric field in the space. The oscillating charges generate varying electric current which in turn is responsible for the generation of periodical varying magnetic field. This way the electromagnetic waves are generated.

9. The wavelength of light from the spectral emission line of sodium is 590 nm. Find the kinetic energy at which the electron would have the same de-Broglie wavelength. [2]

Answer : Given, $\lambda = 590 \text{ nm} = 590 \times 10^{-9} \text{ m}$

KE = ?

For same de-Broglie wavelength,

$$\text{De-Broglie wavelength } (\lambda) = \frac{h}{mv}$$

h -planck constant

$$\begin{aligned} \frac{h}{m_e \times 590 \times 10^{-9}} &= v \\ &= 590 \times 10^{-9} \\ \text{KE} &= \frac{1}{2} m_e v^2 \\ &= \frac{1}{2} \times m_e \times \frac{h^2}{m_e^2 \times (590 \times 10^{-9})^2} \end{aligned}$$

$$= \frac{1}{2} \times \frac{6.62 \times 10^{-34} \times 6.62 \times 10^{-34} \times 10^9 \times 10^9}{9.1 \times 10^{-31} \times 590 \times 590}$$

$$\text{KE} = 6.91 \times 10^{-17} \text{ J}$$

SECTION-C

13. (a) Draw the energy level diagram for the line spectra representing Lyman series and Balmer series in the spectrum of hydrogen atom.

- (b) Using the Rydberg formula for the spectrum of hydrogen atom, calculate the largest and shortest wavelengths of the emission lines of the Balmer series in the spectrum of hydrogen atom. (Use the value of Rydberg constant $R = 1.1 \times 10^7 \text{ m}^{-1}$) [3]

Answer :

- (a) Energy level diagram showing lyman and balmer series :

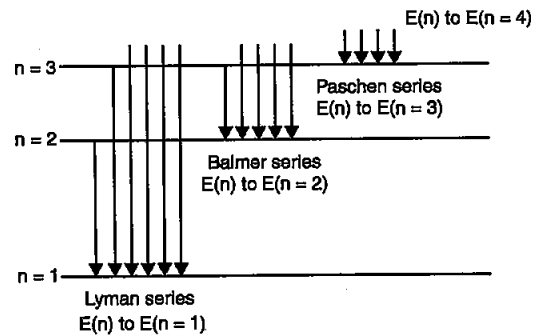

Spectrum wavelengths of both series for hydrogen atom

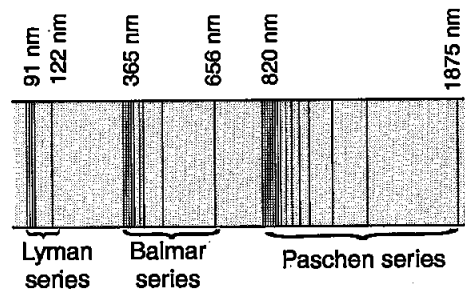

- (b) Rydberg formula,

$$\frac{1}{\lambda} = 1.1 \times 10^7 \left[\frac{1}{n_1^2} - \frac{1}{n_2^2} \right]$$

$$\frac{1}{\lambda_1} = 1.1 \times 10^7 \left[\frac{1}{4} - \frac{1}{9} \right]$$

$$\frac{1}{\lambda_1} = 1.1 \times 10^7 \times 0.1389$$

$$\lambda_1 = \frac{1}{1.1 \times 10^7 \times 0.1389}$$

$$\lambda_1 = \frac{100 \times 10^{-9}}{0.153}$$

$$\lambda_{\max} (\lambda_1) = 653.6 \text{ nm}$$

$$\frac{1}{\lambda_2} = \frac{1.1 \times 10^7}{4}$$

$$\lambda_2 = \frac{4}{1.1 \times 10^7}$$

$$= \frac{400}{1.1} \times 10^{-9}$$

$$\lambda_{\min} (\lambda_2) = 363.6 \text{ nm}$$

$$\frac{1}{C_1} = \frac{1}{12} + \frac{1}{4}$$

$$\frac{1}{C_1} = \frac{4}{12} \mu\text{F}$$

$$C_1 = 3 \mu\text{F}$$

$$C_2 = 3 + 6 = 9 \mu\text{F}$$

$$\frac{1}{C_{\text{eq}}} = \frac{1}{C_1} + \frac{1}{C_2} = \frac{1}{9} + \frac{1}{3}$$

$$\frac{1}{C_{\text{eq}}} = \frac{4}{9}$$

$$C_{\text{eq}} = 9/4 \mu\text{F}$$

15. In a network, four capacitors C_1, C_2, C_3 and C_4 are connected as shown in the figure. [3]

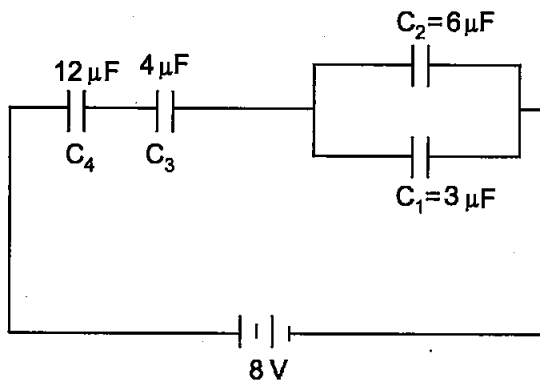

(a) Calculate the net capacitance in the circuit.

(b) If the charge on the capacitor C_1 is $6 \mu\text{C}$, (i) calculate the charge on the capacitors C_3 and C_4 , and (ii) net energy stored in the capacitors C_3 and C_4 connected in series.

Answer :

(a)

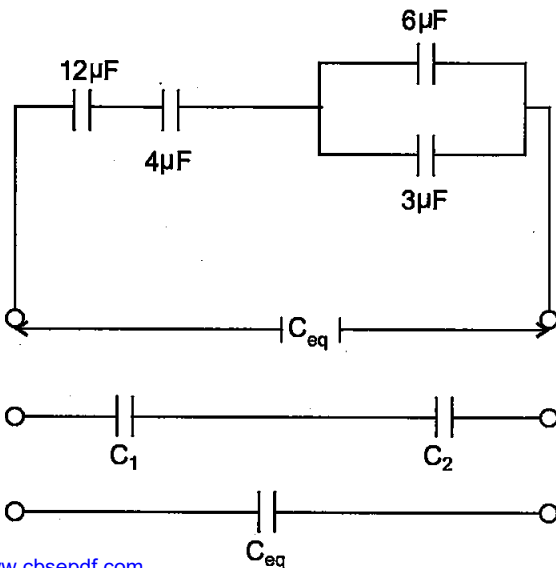

(b) (i) Given, $Q_1 = 6 \mu\text{C}$, $C_2 = 6 \mu\text{F}$

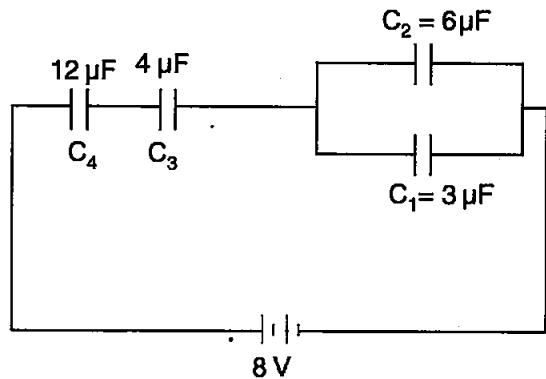

Q_1 is charge on C_1

Q_2 is charge on C_2

Q is net charge flows through C_3 and C_4

$$\frac{Q_1}{C_1} = V = \frac{Q_2}{C_2}$$

$$Q_2 = \frac{Q_1}{C_1} \times C_2$$

$$= \frac{6}{3} \times 6$$

$$Q_2 = 12 \mu\text{C}$$

$$Q = Q_1 + Q_2$$

$$= 12 + 6$$

$$= 18 \mu\text{C}$$

(ii) Voltage across C_1 and C_2 is 2 volts.

Thus, voltage across combination of C_4 and C_3 will be

$$V = 8 - 2 = 6\text{V}$$

$$\frac{1}{C} = \frac{1}{C_3} + \frac{1}{C_4}$$

$$\frac{1}{C} = \frac{1}{4} + \frac{1}{12}$$

$$\frac{1}{C} = \frac{3+1}{12} = \frac{4}{12}$$

$$C = 3 \mu\text{F}$$

Hence, Energy

$$E = \frac{1}{2} CV^2$$

$$= \frac{1}{2} \times 3 \times 6^2$$

$$= \frac{36 \times 3}{2}$$

$$= 54 \times 10^{-6} \text{ J}$$

17. Draw the circuit diagram of a full wave rectifier. Explain its working principle. Show the input waveforms given to the diodes D_1 and D_2 and the corresponding output waveforms obtained at the load connected to the circuit. [3]

Answer :

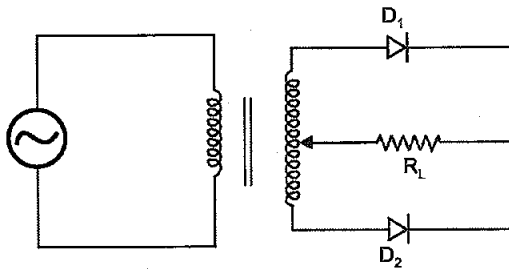

Full wave rectifier

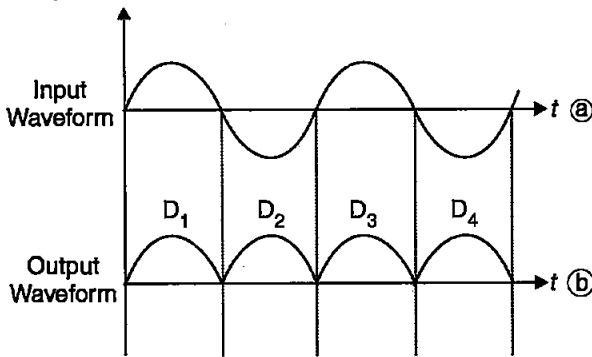

During first half of input sinusoidal ac signal diode D_1 conducts as it is forward bias and during second half of input ac signal diode D_2 conducts as it is forward bias now. D_2 and D_1 are inverse bias conditions during first and second half respectively and doesn't conduct. Due to this output appears as waveform (b).

21. (a) When a convex lens of focal length 30 cm is in contact with a concave lens of focal length 20 cm, find out if the system is converging or diverging.

- (b) Obtain the expression for the angle of incidence of a ray of light which is incident on the face of a prism of refracting angle A so that it suffers total internal reflection at the other face. (Given the refractive index of the glass of the prism is μ) [3]

Answer :

(a) $f_1 = f_{\text{convex}} = 30 \text{ cm}$
 $f_2 = f_{\text{concave}} = -20 \text{ cm}$

$$\frac{1}{f} = \frac{1}{f_1} + \frac{1}{f_2}$$

$$= \frac{1}{30} - \frac{1}{20}$$

$$= \frac{2-3}{60}$$

$$\frac{1}{f} = -\frac{1}{60} [\because \text{concave (diverging) lens}]$$

(b)
$$\mu = \frac{\sin\left(\frac{\delta_{\text{min}} + A}{2}\right)}{\sin A/2}$$

Let C is the critical angle,

$$\sin C = \frac{1}{\mu}$$

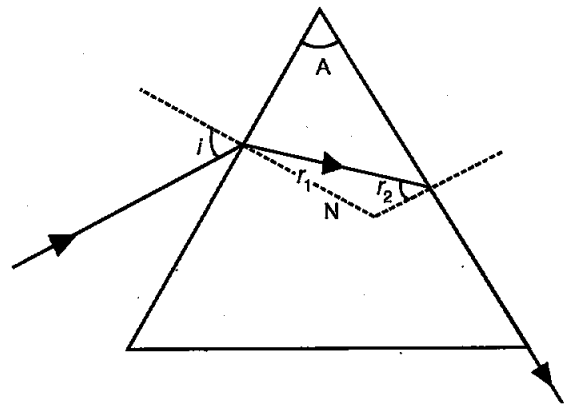

$r_2 = C$ for total internal reflection

$$r_1 + r_2 = A$$

$$r_1 + C = A$$

$$r_1 = A - C$$

$$\mu = \frac{\sin i}{\sin r_1}$$

$$\Rightarrow \sin i = \mu \sin r_1$$

$$\sin i = \mu \sin (A - C)$$

$$i = \sin^{-1} \mu \sin (A - C)$$

Physics 2019 (Delhi)

SET I

Time allowed : 3 hours

Maximum marks : 70

SECTION-A

1. Draw the pattern of electric field lines, when a point charge $-Q$ is kept near an uncharged conducting plate. [1]

Answer :

The positive charge will be induced on the uncharged conducting plate, kept near it. So, the lines of forces will start from metal plate and end at $-Q$.

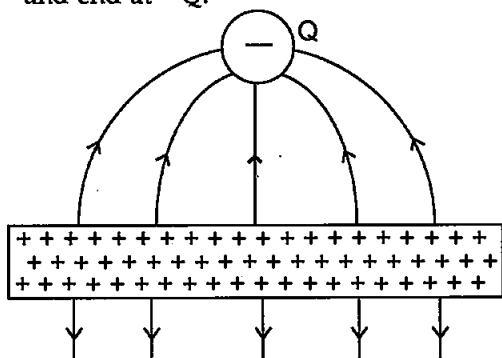

2. How does the mobility of electrons in a conductor change, if the potential difference applied across the conductor is doubled, keeping the length and temperature of the conductor constant? [1]

Answer :

The mobility of electrons is given by the

$$\text{expression, } \mu = \frac{e\tau}{m}$$

As it's independent of the applied potential difference, so it will not change if the applied potential difference will be doubled.

3. Define the term "threshold frequency" in the context of photoelectric emission. [1]

OR

Define the term 'Intensity' in photon picture of electromagnetic radiation.

Answer :

The minimum frequency of the radiation incident on a metal surface below which there is no photoelectric emission is called threshold frequency. It is a characteristic property of a photosensitive material.

OR

The amount of light energy or photon energy incident per meter square per second is called

intensity of radiation. SI unit of intensity of radiation is $\frac{W}{Sr}$.

4. What is the speed of light in a denser medium of polarising angle 30° ? [1]

Answer :

Given : $i_p = 30^\circ$

since, $\mu = \tan i_p$ (By Brewster's law)

$$\therefore \mu = \tan 30^\circ$$

$$\Rightarrow \mu = \frac{1}{\sqrt{3}}$$

$$\text{Since, } \mu = \frac{C}{v}$$

$$\therefore v = \text{velocity of light in medium} = \frac{C}{\mu}$$

$$= \frac{3 \times 10^8}{1/\sqrt{3}}$$

$$= 3\sqrt{3} \times 10^8 \text{ m/s}$$

$$= 5.196 \times 10^8 \text{ m/s}$$

5. In sky wave mode of propagation, why is the frequency range of transmitting signals restricted to less than 30 MHz? [1]

OR

On what factors does the range of coverage in ground wave propagation depend? [1]

SECTION-B

6. Two bulbs are rated (P_1, V) and (P_2, V) . If they are connected (i) in series and (ii) in parallel across a supply V , find the power dissipated in the two combinations in terms of P_1 and P_2 . [2]

Answer : (i) In series combination :

Net resistance, $R' = R_1 + R_2$ (i)

As heating elements are operated at same voltage V , we have

$$R = \frac{V^2}{P}, R_1 = \frac{V^2}{P_1} \text{ and } R_2 = \frac{V^2}{P_2}$$

\therefore From equation (i)

$$\frac{V^2}{P} = \frac{V^2}{P_1} + \frac{V^2}{P_2}$$

$$\Rightarrow \frac{1}{P} = \frac{1}{P_1} + \frac{1}{P_2}$$

\Rightarrow Net power dissipated :

$$\Rightarrow P = \frac{P_1 P_2}{P_1 + P_2}$$

(ii) In parallel combination :

Net resistance,

$$\frac{1}{R} = \frac{1}{R_1} + \frac{1}{R_2} \quad \dots(ii)$$

$$\Rightarrow \frac{P}{V^2} = \frac{P_1}{V^2} + \frac{P_2}{V^2}$$

$$\left[\because R = \frac{V^2}{P}, R_1 = \frac{V^2}{P_1}, R_2 = \frac{V^2}{P_2} \right]$$

$$\Rightarrow P = P_1 + P_2$$

Hence, net power dissipated is $P = P_1 + P_2$.

7. Calculate the radius of curvature of an equi-concave lens of refractive index 1.5, when it is kept in a medium of refractive index 1.4, to have a power of -5 D ? [2]

OR

An equilateral glass prism has a refractive index 1.6 in air. Calculate the angle of minimum deviation of the prism, when kept in a medium of refractive index $4\sqrt{2}/5$.

Answer :

In an equi-concave lens, radius of curvature of both surfaces are equal

$$\therefore \frac{1}{f} = (\mu - 1) \left(-\frac{1}{R} - \frac{1}{R} \right)$$

since, $P = -5\text{ D}$

$$\therefore \frac{1}{f(m)} = P = -5$$

and $\mu_e = 1.5$ and $\mu_m = 1.4$

$$\therefore 5 = \left(\frac{1.5}{1.4} - 1 \right) \left(\frac{-2}{R} \right)$$

$$\Rightarrow -5 = \frac{0.1}{1.4} \times \frac{-2}{R}$$

$$\Rightarrow R = \frac{0.1 \times (-2)}{1.4 \times (-5)}$$

$$= 0.03\text{ m}$$

OR

As we know,

$$n_2 = \frac{\sin \left(\frac{A + \delta_{\min}}{2} \right)}{\sin \frac{A}{2}}$$

where $n_2 = 1.6$, refractive index of glass prism

$$n_1 = \frac{4\sqrt{2}}{5}, \text{ refractive index of medium}$$

$A = 60^\circ$, angle of prism

δ_{\min} = angle of minimum deviation

$$\therefore \frac{1.6}{4\sqrt{2}/5} = \frac{\sin \left(\frac{60^\circ + \delta_m}{2} \right)}{\sin 30^\circ}$$

$$\Rightarrow \frac{0.4 \times 5}{\sqrt{2}} = \sin \left(\frac{60^\circ + \delta_m}{2} \right) \times 2 \left[\because \sin 30^\circ = \frac{1}{2} \right]$$

$$\Rightarrow \sin \left(\frac{60^\circ + \delta_m}{2} \right) = \frac{1}{\sqrt{2}}$$

$$\Rightarrow \frac{60^\circ + \delta_m}{2} = \sin^{-1} \left(\frac{1}{\sqrt{2}} \right)$$

$$= \sin^{-1} (\sin 45^\circ) = 45^\circ$$

$$\Rightarrow \delta_m = 30^\circ$$

8. An α -particle and a proton of the same kinetic energy are in turn allowed to pass through a magnetic field \vec{B} , acting normal to the direction of motion of the particles. Calculate the ratio of radii of the circular paths described by them. [2]

Answer :

As we know, radius of the charged particle is given by

$$r = \frac{\sqrt{2mK}}{qB}$$

Since, K. E. of particles and \vec{B} are equal.

\therefore For α - particle

$$r_\alpha = \frac{\sqrt{2m_\alpha K}}{q_\alpha B} \quad \dots(i)$$

For proton,

$$r_p = \frac{\sqrt{2m_p K}}{q_p B} \quad \dots(ii)$$

on comparing equation (i) and (ii)

$$\frac{r_\alpha}{r_p} = \frac{\sqrt{m_\alpha} \times q_p}{q_\alpha \times \sqrt{m_p}}$$

since, $m_\alpha = 4m_p$ and $q_\alpha = q_p$

$$\therefore \frac{r_\alpha}{r_p} = \frac{\sqrt{4m_p}}{\sqrt{m_p}} = \frac{2}{1}$$

$$r_\alpha : r_p = 2 : 1$$

9. State Bohr's quantization condition of angular momentum. Calculate the shortest wavelength of the Bracket series and state to which part of the electromagnetic spectrum does it belong. [2]

OR

Calculate the orbital period of the electron in the first excited state of hydrogen atom.

Answer : According to Bohr's quantization of angular momentum, the stationary orbits are those in which angular momentum of electron

is an integral multiple of $\frac{h}{2\pi}$ i.e.,

$$mvr = n \frac{h}{2\pi} \text{ Where, } n = 1, 2, 3$$

For Brackett series,

$$\frac{1}{\lambda_{\min}} = n = \frac{1}{\sin C}$$

$$\Rightarrow \frac{1}{\lambda_{\min}} = \frac{R}{16}$$

Where, $R = \text{Rydberg constant} = 1.096 \times 10^7 \text{ m}^{-1}$

$$\Rightarrow \lambda_{\min} = \frac{16}{1.096 \times 10^7} \text{ m}$$

$$= 14.599 \times 10^{-7}$$

$$\Rightarrow = 14599 \text{ \AA}$$

Brackett series is found in infrared region (10^6 \AA to 7000 \AA) of electromagnetic spectrum.

OR

For hydrogen atom $z=1$ and $n = 1$

\therefore Velocity of electron,

$$v = \frac{ze^2}{2h\epsilon_0 n}$$

$$v = \frac{e^2}{2h\epsilon_0}$$

Therefore, $v = \frac{c}{137}$, Where, c is velocity of light.

$$\text{Orbital period} = \frac{\text{Distance}}{\text{Velocity}} = \frac{2\pi r}{c} \times 137$$

$$= \frac{2 \times 3.14 \times 5.29 \times 10^{-11} \times 137}{3 \times 10^8}$$

$$= 1.517 \times 10^{-16} \text{ sec.}$$

10. Why a signal transmitted from a TV tower cannot be received beyond a certain distance? Write the expression for the optimum separation between the receiving and the transmitting antenna.** [2]

11. Why is wave theory of electromagnetic radiation not able to explain photo electric effect? How does photon picture resolve this problem? [2]

Answer :

Wave theory cannot explain the following laws of photoelectric effect.

- (i) The instantaneous emission of photoelectrons.
- (ii) Existence of threshold frequency for metal surface.
- (iii) K.E. of emitted electrons is independent of intensity of light and depends on frequency.

The concept of photon explained that energy is not only emitted and absorbed in discrete energy quanta, but also it propagates through space in definite quanta with the speed of light. It can explain all the above photoelectric effect, which wave theory cannot explain.

12. Plot a graph showing variation of de Broglie wavelength (λ) associated with a charged particle of a mass m , versus $1/\sqrt{V}$, where V is the potential difference through which the particle is accelerated. How does this graph give us the information regarding the magnitude of the charge of the particle? [2]

Answer :

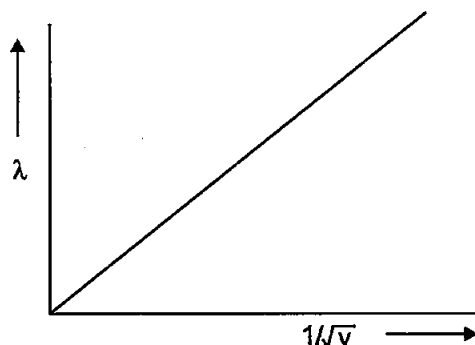

Since, $\lambda = \frac{h}{\sqrt{2meV}}$

i.e., $\lambda \propto \frac{1}{\sqrt{e}}$

Therefore, more the wavelength lesser is the charge.

SECTION-C

- 13. (a) Draw the equipotential surfaces corresponding to a uniform electric field in the z-direction.
- (b) Derive an expression for the electric potential at any point along the axial line of an electric dipole. [3]

Answer :

(a)

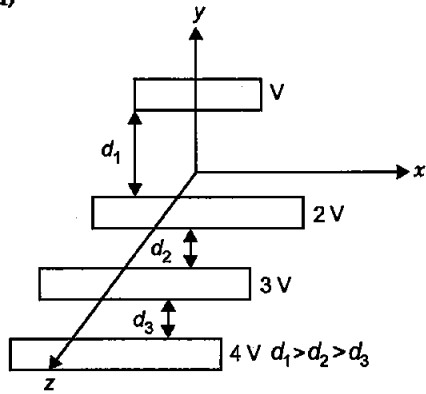

(b) Electric potential due to dipole along axial line :

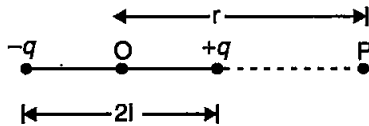

The figure shows a dipole consisting of two equal and opposite charges $+q$ and $-q$ separated by a distance $2l$. Let, P be a point on the end-on position of the dipole. OP is the axial line of dipole.

The potential due to charge $+q$ at point

$$P = V_1$$

$$V_1 = \frac{1}{4\pi\epsilon_0} \times \frac{q}{(r-l)}$$

The potential due to charge $-q$ at point $P = V_2$

$$V_2 = \frac{1}{4\pi\epsilon_0} \times \frac{(-q)}{(r+l)}$$

Total potential at point $P = V = V_1 + V_2$

$$V = \frac{1}{4\pi\epsilon_0} \times \frac{q}{(r-l)} + \frac{1}{4\pi\epsilon_0} \times \frac{(-q)}{(r+l)}$$

$$= \frac{q}{4\pi\epsilon_0} \left[\frac{1}{r-l} - \frac{1}{r+l} \right]$$

$$= \frac{q}{4\pi\epsilon_0} \left[\frac{r+l-r+l}{(r-l)(r+l)} \right]$$

$$= \frac{1}{4\pi\epsilon_0} \frac{2ql}{(r-l)(r+l)}$$

$$= \frac{1}{4\pi\epsilon_0} \frac{2ql}{(r^2 - l^2)}$$

But the dipole moment, $P = 2ql$

So,

$$V = \frac{1}{4\pi\epsilon_0} \times \frac{P}{(r^2 - l^2)}$$

14. Using Kirchhoff's rules, calculate the current through the 40Ω and 20Ω resistors in the following circuit : [3]

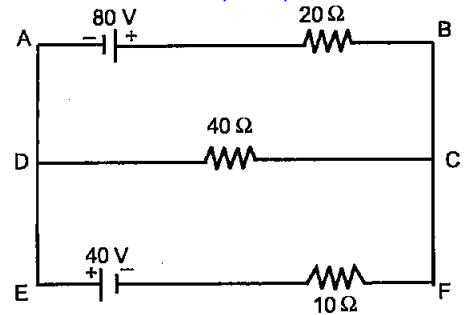

OR

What is end error in a metre bridge? How is it overcome? The resistances in the two arms of the metre bridge are $R = 5 \Omega$ and S respectively.

When the resistance S is shunted with an equal resistance, the new balance length found to be $1.5 l_1$, where l_1 is the initial balancing length. Calculate the value of S .

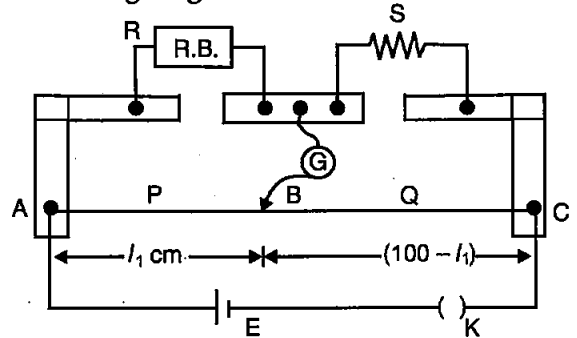

Answer :

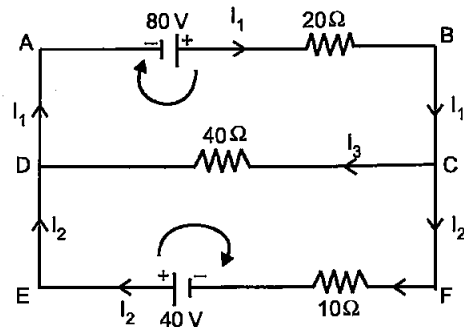

Applying Kirchhoff's first law at junction C

$$I_1 = I_2 + I_3$$

$$I_2 = I_1 - I_3 \quad \dots(i)$$

Applying the Kirchhoff's second law in closed loop ABCDA

$$80 - 20 I_1 - 40 I_3 = 0 \quad \dots(ii)$$

Applying Kirchhoff's second law in closed loop DCFED

$$40 I_3 - 10 I_2 + 40 = 0 \quad \dots(iii)$$

From equations (i) and (iii),

$$40 I_3 - 10 (I_1 - I_3) - 40 = 0$$

$$50 I_3 - 10 I_1 + 40 = 0 \quad \dots(iv)$$

From equations (ii) and (iv)

$$80 = 20 I_1 + 40 I_3$$

$$40 = 10 I_1 + 50 I_3$$

We get, $I_3 = 0$

and $I_1 = 4 \text{ A}$

$$I_2 = 4 \text{ A}$$

Therefore, current through 40Ω resistor is 0 and current through 20Ω resistor is 4 A.

OR

The shifting of zero of the scale at different points give rise to the end error in metre bridge wire.

This can be overcome by,

1. By trying to obtain the balance point in the middle of the metre bridge.
2. By taking metre bridge wire of uniform cross-section
3. By taking the copper strips thick, so that their resistance can be ignored.

As we know that,

$$\frac{R}{S} = \frac{l_1}{100 - l_1} \quad \dots(i)$$

When resistance S is shunted with equal resistance. Then, $S' = \frac{S}{2}$

Therefore, new balancing point is,

$$\Rightarrow \frac{R}{S/2} = \frac{1.5 l_1}{100 - 1.5 l_1}$$

$$\Rightarrow \frac{R}{S} = \frac{1.5 l_1}{2(100 - 1.5 l_1)} \quad \dots(ii)$$

On comparing equations (i) and (ii)

$$\frac{l_1}{100 - l_1} = \frac{1.5 l_1}{2(100 - 1.5 l_1)}$$

$$200 - 3l_1 = 150 - 1.5l_1$$

$$1.5 l_1 = 50$$

$$l_1 = \frac{50}{1.5}$$

From equatoin (i),

$$\frac{5}{S} = \frac{50}{1.50} \left(100 - \frac{50}{1.5} \right) \quad (\because R = S)$$

$$\Rightarrow \frac{5}{S} = \frac{50 \times 1.5}{1.5(100)}$$

$$\Rightarrow S = \frac{500}{5} = 10 \Omega$$

(b) Prove that the average energy density of the oscillating electric field is equal to that of the oscillating magnetic field. [3]

Answer : (a)

(i) Radar—Microwaves are used in radar. The frequency range is from $3 \times 10^{11} \text{ Hz}$ to $1 \times 10^9 \text{ Hz}$.

(ii) Eye Surgery—Infrared waves are used. The frequency range is from $4 \times 10^{14} \text{ Hz}$ to $3 \times 10^{11} \text{ Hz}$.

(b) Energy density in oscillating electric field is -

$$u_E = \frac{1}{2} \epsilon_0 E^2$$

Energy density in oscillating magnetic field is-

$$u_B = \frac{1}{2\mu_0} B^2$$

We know, $E = cB$

$$\text{And } c = \frac{1}{\sqrt{\mu_0 \epsilon_0}}$$

$$\begin{aligned} \text{So, } u_E &= \frac{1}{2} \epsilon_0 (cB)^2 = \frac{1}{2} \epsilon_0 \frac{1}{\mu_0 \epsilon_0} \times B^2 \\ &= \frac{1}{2\mu_0} B^2 \end{aligned}$$

$$\text{So, } u_E = u_B$$

16. Define the term wavefront. Using Huygen's wave theory, verify the law of reflection. [3]

OR

Define the term, "refractive index" of a medium. Verify Snell's law of refraction when a plane wavefront is propagating from a denser to a rarer medium.

Answer :

A wavefront is the continuous locus of vibrating particles which are in the same state of vibration or phase.

Laws of Reflection from Huygen's principle

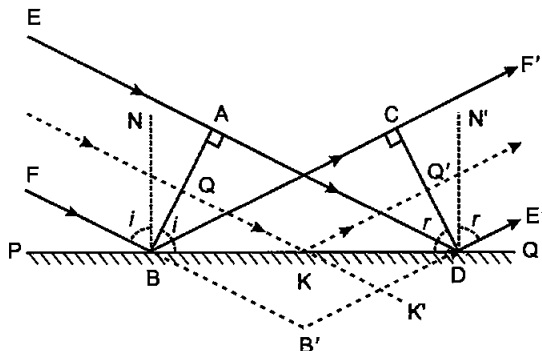

Consider a plane wavefront AB incident on a plane reflecting surface PQ . Let v be the velocity of the wave. At time $t = 0$ one end of the wavefront just touches the reflecting surface at B . Draw normal NB to PQ . When the wavefront strikes the reflecting surface,

then due to the presence of it, it cannot advance further. When wavefront strikes at B, secondary wavelets starts emitting from B. The secondary wavelets will travel a distance $AD = vt$ during the time the other end A of the wavefront AB reaches the surface PQ at Q.

To find the reflected wavefront, B as a centre and AD as radius draw an arc, which represent the secondary wavelets originating from B. As the incident wavefront AB advances, the secondary wavelets will touch CD simultaneously.

According to Huygen's principle CD represents the reflected wavefront corresponding to incident wavefront AB. BD is common triangles BAD and CBD and $BC = AD = vt$. Therefore, two triangles are congruent.

So, $\angle ABD = \angle CDB$

i.e., $\angle i = \angle r$

Thus, angle of incidence is equal to the angle of reflection. This is the second law of reflection.

Also, the incident wavefront AB, reflecting surface PQ and the reflected wavefront CD are perpendicular to the plane of the paper. So, the incident ray, reflected ray and the normal at the point of incidence, all lie in same plane.

This is first law of reflection.

Thus, Huygen's principle explains both the law of reflection.

OR

The refractive index of a medium is defined as the ratio of speed of light in vacuum to that of the speed of the light in medium.

i.e.,
$$n = \frac{c}{v}$$

Where, n = refractive index of medium when light ray passes from vacuum into a medium.

c = velocity of light in vacuum

v = velocity of light in the medium

Proof of Snell's law of refraction

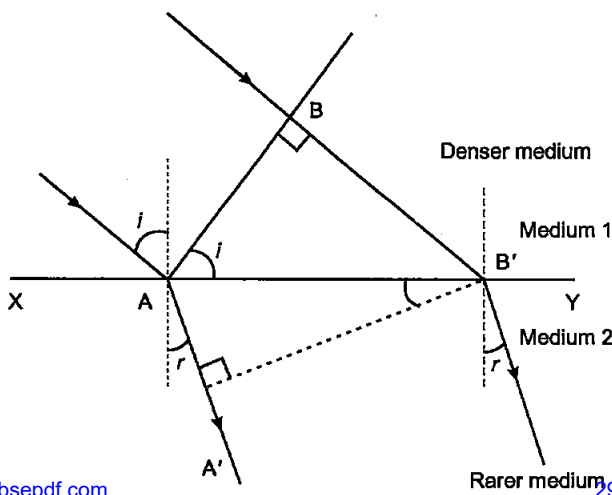

when a wavefront travels from one medium to other, it deviates from its path. In travelling from one medium to other, the frequency of wave remains same and speed and wavelength changes. Let, XY be a surface separating two media '1' and '2'. Let the speed of waves of v_1 and v_2 .

Suppose, a plane wavefront AB in first medium is incident obliquely on the boundary surface XY and its end touches the surface at A at time $t = 0$, while the other end B reaches the surface at point B' after time-interval 't'

Clearly, $BB' = v_1 t$.

In the same time, wavelets starts from A and reaches A' in time 't' with velocity v_2 .

Therefore, $AA' = v_2 t$

According to Huygen's principle, A'B' is the new position of the wavefront in second medium. A'B' is a refracted wavefront.

Let, the incident wavefront (AB) and reflected wavefront (A'B') makes angle i and r with surface XY.

In $\triangle AB'B$,

$\angle ABB' = 90^\circ$

$\therefore \sin i = \frac{BB'}{AB'} = \frac{v_1 t}{AB'} \dots (i)$

In $\triangle AA'B'$,

$\angle AA'B' = 90^\circ$

$\therefore \sin r = \frac{AA'}{AB'} = \frac{v_2 t}{AB'} \dots (ii)$

Dividing equation (i) by (ii), we get

$$\frac{\sin i}{\sin r} = \frac{v_1}{v_2} = \text{constant}$$

Hence, ratio of sine of angle of incidence and the sine of angle of refraction for a given pair of media is constant. This is Snell's law of refraction.

17. (a) Define mutual inductance and write its S.I. unit.

(b) A square loop of side 'a' carrying a current I_2 is kept at distance x from an infinitely long straight wire carrying a current I_1 as shown in the figure. Obtain the expression for the resultant force acting on the loop. [3]

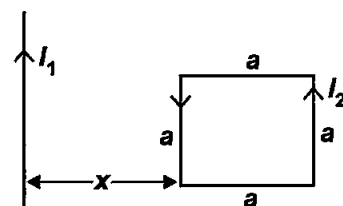

Answer :

(a) **Mutual inductance :** It is a property of two coils due to which each coil opposes any change

of current flowing in the other. The mutually induced e.m.f, in one coil produces the opposition in other coil.

Its SI unit is henry (H).

(b)

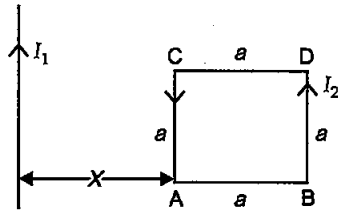

The resultant magnetic force of sides AB and DC is zero. The force on side AD is repulsive and on side BC is attractive. Since, AD is near the straight wire. So, the net force will be repulsive.

Force on side AD,

$$F_1 = \frac{\mu_0 I_1 I_2 a}{2\pi x} \quad (\text{away from wire})$$

Force on side BC,

$$F_2 = \frac{\mu_0 I_1 I_2}{2\pi (x+a)} \times a \quad (\text{towards the wire})$$

Therefore, resultant force,

$$F = F_1 - F_2 = \frac{\mu_0 I_1 I_2 a}{2\pi} \left(\frac{1}{x} - \frac{1}{x+a} \right)$$

$$F = \frac{\mu_0 I_1 I_2 a}{2\pi} \left(\frac{a}{x(x+a)} \right)$$

$$F = \frac{\mu_0}{2\pi} \times \frac{I_1 I_2 a^2}{x(x+a)}, \quad (\text{away from wire})$$

18. (a) Derive the expression for the torque acting on a current carrying loop placed in a magnetic field.
 (b) Explain the significance of a radial magnetic field when a current carrying coil is kept in it. [3]

Answer : Torque on current carrying loop in magnetic field :

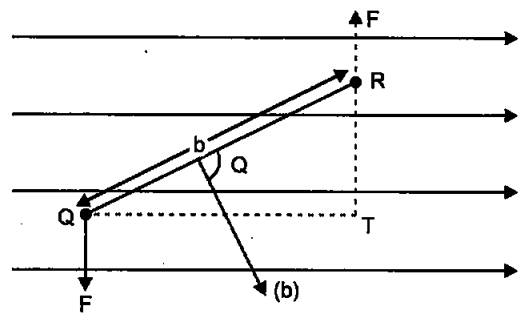
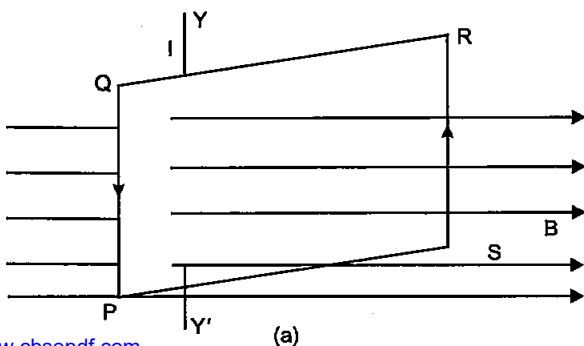

Consider a coil PQRS placed in a magnetic field. Let θ be the angle between the plane of the coil and direction of B. When current flow through coil each side experiences a force. The forces on vertical side will constitute a couple. Moment of torque = One of forces \times Perpendicular distance between lines of action of force

$$\tau = F \times QT = F \times b \sin \theta = I b B \sin \theta$$

$$\tau = I (\vec{A} \times \vec{B}) \quad (\because \text{Area} = lb)$$

If there are N turns, then

$$\tau = N I (\vec{A} \times \vec{B}) = \vec{M} \times \vec{B}$$

Where, $\vec{M} = NI \vec{A}$ is magnetic moment of loop.
 (b) A magnetic field, in which the plane of the coil in all positions remains parallel to the direction of magnetic field is called radial magnetic field. In a radial magnetic field, magnetic torque remains maximum for all the positions of the coil.

19. Draw a labelled ray diagram of an astronomical telescope in the near point adjustment position. A giant refracting telescope at an observatory has an objective lens of focal length 15 m and an eyepiece of focal length 1.0 cm. If this telescope is used to view the Moon, find the diameter of the image of the Moon formed by the objective lens. The diameter of the Moon is 3.48×10^6 m and the radius of lunar orbit is 3.8×10^6 m. [3]

Answer : Astronomical telescope in near points adjustment :

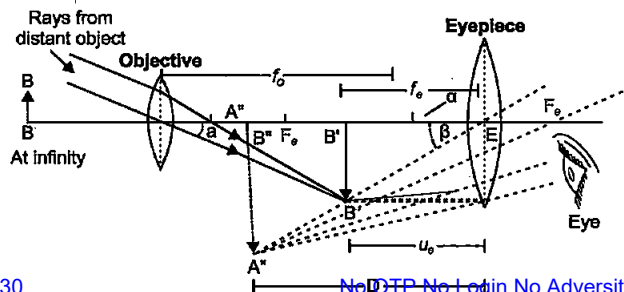

Here, $f_0 = 15 \text{ m}$, $f_e = 1 \text{ cm} = 0.1 \text{ m}$
 Diameter of moon, $d = 3.48 \times 10^6 \text{ m}$
 Radius of lunar orbit $u_0 = 3.8 \times 10^8 \text{ m}$
 size of the image of moon, $I = ?$

The angle subtended by the moon at the objective lens,

$$\alpha = \frac{d}{|u_0|} \quad \dots(i)$$

And the angle subtended by the image of the moon at the objective lens,

$$\beta = \frac{I}{f_0} \quad \dots(ii)$$

Both these angles in equations (i) and (ii) will be equal.

$$\begin{aligned} \therefore \frac{d}{|u_0|} &= \frac{I}{f_0} \\ \Rightarrow I &= \frac{d \times f_0}{|u_0|} \\ &= \frac{3.48 \times 10^6 \times 15}{3.8 \times 10^8} \text{ m} \\ &= 13.73 \times 10^{-2} \text{ m} \\ &= 13.73 \text{ cm} \end{aligned}$$

20. (a) State Gauss' law for magnetism. Explain its significance.

(b) Write the four important properties of the magnetic field lines due to a bar magnet. [3]

OR

Write three points of differences between para-, dia- and ferro-magnetic materials, giving one example for each.

Answer :

(a) Gauss law for magnetism : If a closed surface is imagined in a magnetic field, the number of lines of force emerging from the surface must be equal to the number entering it. That is, the net magnetic flux out of any closed surface is zero.

Gauss law signifies that magnetic monopoles does not exist.

(b)

1. In a bar magnet, each lines of force, starts from a north pole and reaches the south pole externally and then goes from south pole to a north pole internally. Thus, magnetic line of force forms a closed loop.

2. No two lines of force will never intersect each other.

3. In a uniform field, the lines are parallel and equidistant from each other.

4. The lines of force are crowded near the poles.

OR

Properties	Ferro-magnetic Materials	Para-magnetic Materials	Dia-magnetic Materials
State	They are solid	They can be solid, liquid or gas.	They can be solid, liquid or gas.
Effect of Magnet	Strongly attracted by a magnet	Weakly attracted by a magnet.	Weakly repelled by a magnet.
Effect of Temperature	Above curie point, it becomes a paramagnetic.	With the rise of temperature, it becomes a diamagnetic.	No effect.
Examples	Iron, Nickel, Cobalt	Lithium, Molybdenum, magnesium	Copper, Silver, Gold

Note : Any three difference can be written in exam.

21. Define the term 'decay constant' of a radioactive sample. The rate of disintegration of a given radioactive nucleus is 10000 disintegrations/s and 5,000 disintegrations/s after 20 hr. and 30 hr. respectively from start. Calculate the half life and initial number of nuclei at $t = 0$. [3]

Answer :

'Decay constant' of a radioactive sample is defined as the ratio of its instantaneous rate of disintegration to the number of atoms present at that time.

$$\text{i.e., } \frac{dN}{dt} = -\lambda n,$$

$$\lambda = \frac{-dN/dt}{N}$$

Let, the initial number of nuclei be N_0 at $t = 0$

$$\frac{dN}{dt} = 10,000 \quad \text{at } t = 20 \text{ hr}$$

and $\frac{dN'}{dt} = 5,000 \quad \text{at } t = 30 \text{ hr}$

We have, $\frac{dN}{dt} = \lambda N,$

For first case,

$$10,000 = \lambda N, \Rightarrow N = \frac{10,000}{\lambda}$$

and $N = N_0 e^{-\lambda t}$,

$$\frac{10,000}{\lambda} = N_0 e^{-20\lambda} \quad \dots(i)$$

For second case,

$$5,000 = \lambda N'$$

$$N' = \frac{5,000}{\lambda}$$

and $N' = N_0 e^{-30\lambda}$

$$\frac{5,000}{\lambda} = N_0 e^{-30\lambda} \quad \dots(ii)$$

on dividing equation (i) by equation (ii), we get

$$\Rightarrow \frac{e^{-20\lambda}}{e^{-30\lambda}} = 2$$

Taking log on both sides,

$$\Rightarrow -20\lambda + 30\lambda = \log_e 2$$

$$\Rightarrow 10\lambda = 2.302 \times 0.3010$$

$$\Rightarrow \lambda = 0.0693$$

$$\therefore \text{Half life, } \tau = \frac{0.693}{0.0693} = 10 \text{ hr}$$

22. (a) Three photo diodes D_1 , D_2 and D_3 are made of semiconductors having band gaps of 2.5 eV, 2 eV and 3 eV respectively. Which of them will not be able to detect light of wavelength 600 nm ?

(b) Why photodiodes are required to operate in reverse bias? Explain. [3]

Answer :

(a) Energy corresponding to wavelength 600 nm is,

$$E = \frac{hc}{\lambda}$$

$$= \frac{6.6 \times 10^{-34} \times 3 \times 10^8}{600 \times 10^{-9}} \text{ J} = 3.3 \times 10^{-19} \text{ J}$$

$$= \frac{3.3 \times 10^{-19}}{1.6 \times 10^{-19}} \text{ eV} = 2.06 \text{ eV}$$

The photon energy ($E = 2.06 \text{ eV}$) is greater than the band gap for diode D_2 only.

Hence, diode D_1 and D_3 will not be able to detect the given wavelength.

(b) A photodiode is operated reverse bias because in reverse bias it is easier to observe change in current with change in light intensity.

23. (a) Describe briefly the functions of the three segments of n-p-n transistor.**

(b) Draw the circuit arrangement for studying the output characteristics of n-p-n transistor in CE configuration. Explain how the output characteristics is obtained.** [3]

OR

Draw the circuit diagram of a full wave rectifier and explain its working. Also, give the input and output waveforms.

Answer :

OR

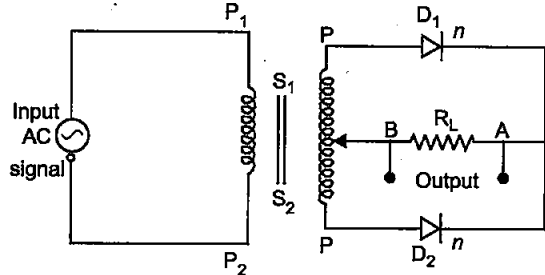

For full wave rectifier, we use two junction diodes as shown in figure.

During first half cycle of input a.c. signal the terminal S_1 is positive relative to S_2 and S_2 is negative, then diode D_1 is in forward biased and diode D_2 is reverse biased. Therefore, current flows in D_1 not in D_2 . In next half cycle, S_1 is negative and S_2 is positive relative to S_1 . Then D_1 is in reverse biased and D_2 is in forward biased. Therefore, current flows in D_2 not in D_1 . Thus, for input a.c. signal the output current is a continuous series of unidirectional pulse.

The input and output waveforms are shown in the figure.

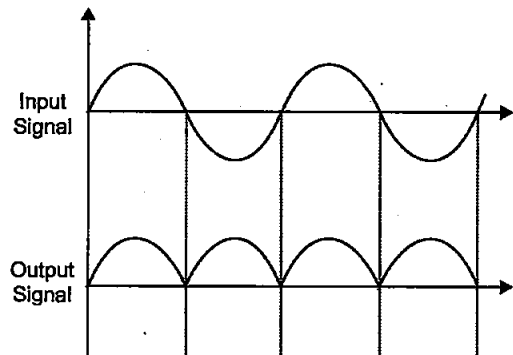

24. (a) If A and B represent the maximum and minimum amplitudes of an amplitude modulated wave, write the expression for the modulation index in terms of A & B.**
- (b) A message signal of frequency 20 kHz and peak voltage 10 V is used to modulate a carrier of frequency 2 MHz and peak voltage

of 15 V. Calculate the modulation index. Why the modulation index is generally kept less than one? [3]

SECTION-D

25. (a) In a series LCR circuit connected across an ac source of variable frequency, obtain the expression for its impedance and draw a plot showing its variation with frequency of the ac source.
- (b) What is the phase difference between the voltages across inductor and the capacitor at resonance in the LCR circuit?
- (c) When an inductor is connected to 200 V dc voltage, a current of 1 A flows through it. When the same inductor is connected to a 200 V, 50 Hz ac source, only 0.5 A current flows. Explain, why? Also, calculate the self inductance of the inductor. [5]

OR

- (a) Draw the diagram of a device which is used to decrease high ac voltage into a low ac voltage and state its working principle. Write four sources of energy loss in this device.
- (b) A small town with a demand of 1200 kW of electric power at 220V is situated 20 km away from an electric plant generating power at 440 V. The resistance of the two wire line carrying power is 0.5 Ω per km. The town gets the power from the line through a 4000-220 V step-down transformer at a sub-station in the town. Estimate the line power loss in the form of heat.

Answer :

(a) Consider an alternating e.m.f. is connected in series with an inductor, resistance R and capacitance C. Let, E and I be the instantaneous values of e.m.f. and current in the LCR circuit V_L , V_C and V_R be the instantaneous values of voltage across inductor, capacitor and resistor respectively. Then,

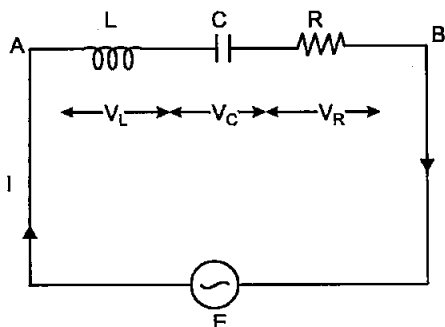

$$V_L = IX_L, V_C = IX_C \text{ and } V_R = IR$$

$$\text{Here, } X_L = \omega L \text{ and } X_C = \frac{1}{\omega C}$$

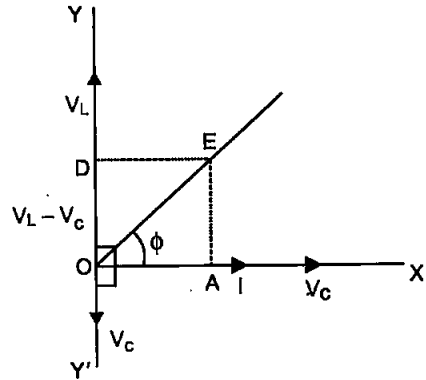

In an a.c. circuit V_R and I are in same phase, V_L leads I by $\pi/2$ and V_C lags I by $\pi/2$. From the graph, in right angled ΔOEA

$$OE = \sqrt{OA^2 + AE^2} = \sqrt{OA^2 + OD^2}$$

$$= \sqrt{V_R^2 + (V_L - V_C)^2}$$

$$\therefore E = \sqrt{(IR)^2 + (IX_L - IX_C)^2}$$

$$E = I\sqrt{R^2 + (X_L - X_C)^2}$$

$$I = \frac{E}{\sqrt{R^2 + (X_L - X_C)^2}}$$

Therefore, effective resistance or impedance of LCR circuit is-

$$Z = \sqrt{R^2 + (X_L - X_C)^2}$$

$$= \sqrt{R^2 + \left(\omega L - \frac{1}{\omega C}\right)^2}$$

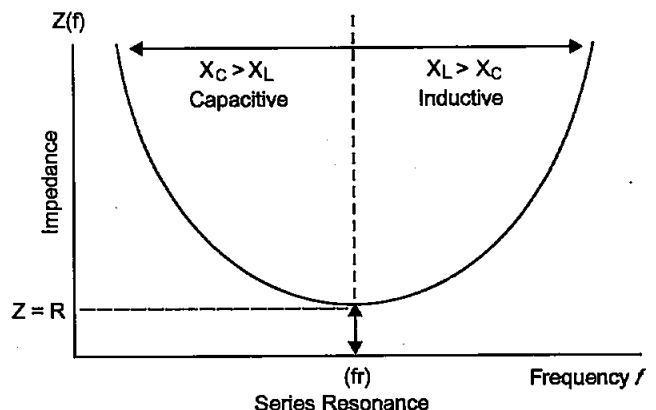

Graph showing variation of impedance with frequency
No OTP No Login No Advertisement

(b) At resonance, $X_L = X_C$

i.e., $iX_L = iX_C$

or $V_L = V_C$

The voltage across inductance and capacitance are equal and have a phase difference of 180° at resonance.

(c) Since the reactance of an inductor is zero for d.c. circuit. But the inductor offers resistance to an a.c. circuit. Therefore, the current decreases for the same inductor when it is connected with an a.c. source.

When inductor is connected in a.c. circuit :

$V = 200 \text{ V}$

$f = 50 \text{ Hz}$

$i = 0.5 \text{ A}$

$i = \frac{V}{R} = \frac{V}{X_L} = \frac{V}{\omega L}$

$0.5 = \frac{200}{2\pi \times 50 L} \quad [\because \omega = 2\pi f]$

$L = \frac{200}{100 \times 0.5 \times 3.14}$

$= \frac{4}{3.14} = 1.27 \text{ H}$

OR

(a) **Step-down transformer :**

It is a device used for converting high alternating voltage at low current into low alternating voltage at high current and vice-versa.

The device works on the principle of mutual induction *i.e.*, if the current or magnetic flux linked with a coil changes then an e.m.f. is induced in the other coil.

In step-down transformer $N_p > N_s$ and transformation ratio is less than 1.

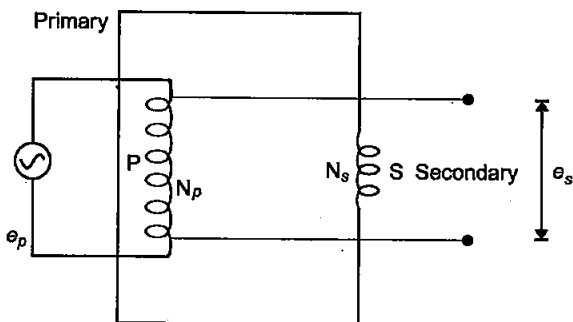

Energy losses are :

- 1. Copper losses :** Due to resistance of windings in primary and secondary coils, some electrical energy is converted into heat energy.
- 2. Flux losses :** Some of the flux produced in primary coil is not linked up with secondary coils.
- 3. Hysteresis losses :** When the iron core is subjected to a cycle of magnetisation the core

gets heated up due to hysteresis known as hysteresis loss.

4. Iron losses : The varying magnetic flux produces eddy current in the iron core, which leads to the wastage of energy in the form of heat.

(b) Length of wire line = $20 \times 2 = 40 \text{ km}$

Resistance of wire line, $r = 40 \times 0.5 = 20 \Omega$

Power to be supplied = $1200 \text{ kW} = 1200 \times 10^3 \text{ W}$

Voltage at which power supplied = 4000 V

Since, $P = VI$

$\Rightarrow I = \frac{P}{V}$

$\Rightarrow I = \frac{1200 \times 10^3}{4000}$
 $= 300 \text{ A}$

Therefore, line power loss

$= I^2 \times R$
 $= (300)^2 \times 20$
 $= 36 \times 10^5 \text{ W}$
 $= 360 \text{ kW}$

\therefore Line power loss in the form of heat is 360 kW .

26. (a) Describe any two characteristic features which distinguish between interference and diffraction phenomena. Derive the expression for the intensity at a point of the interference pattern in Young's double slit experiment.
- (b) In the diffraction due to a single slit experiment, the aperture of the slit is 3 mm . If monochromatic light of wavelength 620 nm is incident normally on the slit, calculate the separation between the first order minima and the 3rd order maxima on one side of the screen. The distance between the slit and the screen is 1.5 m . [5]

OR

- (a) Under what conditions is the phenomenon of total internal reflection of light observed? Obtain the relation between the critical angle of incidence and the refractive index of the medium.
- (b) Three lenses of focal length $+10 \text{ cm}$, -10 cm and $+30 \text{ cm}$ are arranged coaxially as in the figure given below. Find the position of the final image formed by the combination.

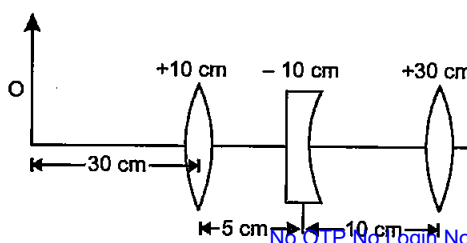

Answer : (a)

	Interference	Diffraction
1.	It is the result of interaction of light coming from two different wavefronts originating from two coherent sources.	1. It is the result of interaction of light come from different parts of same wavefronts.
2.	All the bright fringes are of same intensity.	2. The bright fringes are of varying intensity (Intensity of bright fringes decreases from central bright fringe on either sides.)

A sources of monochromatic light illuminates two narrow slits S_1 and S_2 . The two illuminated slits act as the two coherent sources. The two slits is very close to each other and at equal distance from source. The wavefront S_1 and S_2 spread in all direction and superpose and produces dark and bright fringe on screen. Let the displacement of waves from S_1 and S_2 at point P on screen at time t is-

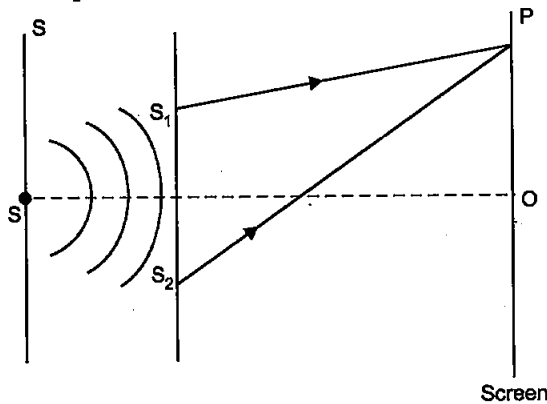

$$y_1 = a_1 \sin \omega t$$

$$y_2 = a_2 \sin (\omega t + \phi)$$

The resultant displacement at point P is given by

$$y = y_1 + y_2$$

$$= a_1 \sin \omega t + a_2 \sin (\omega t + \phi)$$

$$= a_1 \sin \omega t + a_2 \sin \omega t \cos \phi + a_2 \cos \omega t \sin \phi$$

$$= (a_1 + a_2 \cos \phi) \sin \omega t + a_2 \sin \phi \cos \omega t \dots (i)$$

Let, $a_1 + a_2 \cos \phi = A \cos \theta \dots (ii)$

$a_2 \sin \phi = A \sin \theta \dots (iii)$

Therefore, equation (i) becomes

$$y = A \cos \theta \sin \omega t + A \sin \theta \cos \omega t$$

$$= A \sin (\omega t + \theta)$$

This is the resultant displacement.

Now, squaring and adding equations (ii) and (iii)

$$A^2 \cos^2 \theta + A^2 \sin^2 \theta = (a_1 + a_2 \cos \phi)^2 + a_2^2 \sin^2 \phi$$

$$A^2 = a_1^2 + a_2^2 + 2a_1 a_2 \cos \phi$$

The intensity of light is directly proportional to the square of the amplitude

i.e., $I = a_1^2 + a_2^2 + 2a_1 a_2 \cos \phi$
This is the expression for intensity at a point of interference pattern.

or $I = I_1 + I_2 + 2\sqrt{I_1 I_2} \cos \phi$

(b) Here, $\lambda = 620 \text{ nm} = 620 \times 10^{-9} \text{ m}$

$a = 3 \times 10^{-3} \text{ m}$, $D = 1.5 \text{ m}$

Distance of first order minima from the centre,

$$y_1 = \frac{D\lambda}{a} = \frac{1.5 \times 620 \times 10^{-9}}{3 \times 10^{-3}}$$

$$= 3.1 \times 10^{-4} \text{ m}$$

Distance of third order maxima on the same side,

$$y_2 = \frac{7D\lambda}{2a} = \frac{7 \times 1.5 \times 620 \times 10^{-9}}{2 \times 3 \times 10^{-3}}$$

$$= 10.85 \times 10^{-4} \text{ m}$$

Separation between them.

$$y = y_2 - y_1$$

$$= 10.85 \times 10^{-4} - 3.1 \times 10^{-4}$$

$$= 7.75 \times 10^{-4} \text{ m}$$

OR

(a) Conditions for total internal refraction :

1. The ray must travel from a denser medium into a rarer medium.
2. The angle of incidence in the denser medium must be greater than the critical angle for the pair of media.

Relation between critical angle and refractive index :

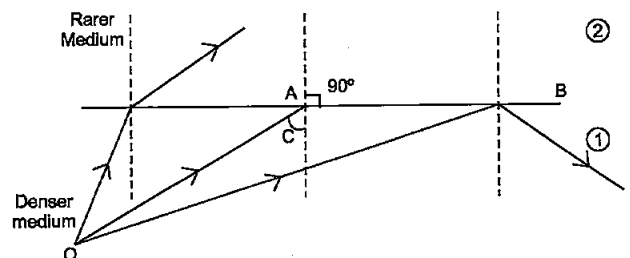

When a ray of light travels from denser to rarer medium, the ray bends away from the normal. When the angle of incidence is equal to the critical angle then the refracted ray grazes the surface of separation represented by ray OA and AB.

By Snell's law

$$\frac{\sin i}{\sin r} = \frac{1}{n}$$

where, $i = C$, $r = 90^\circ$ and $n =$ refractive index of denser medium.

$$\begin{aligned} \therefore \frac{\sin C}{\sin 90^\circ} &= \frac{1}{n} \\ n &= \frac{1}{\sin C} \end{aligned}$$

(b) For first lens, $u_1 = -30$ cm, $f_1 = 10$ cm

\therefore From lens formula,

$$\begin{aligned} \frac{1}{f_1} &= \frac{1}{v_1} - \frac{1}{u_1} \\ \Rightarrow \frac{1}{v_1} &= \frac{1}{f_1} + \frac{1}{u_1} \\ &= \frac{1}{10} - \frac{1}{30} \end{aligned}$$

$$\Rightarrow v_1 = 15 \text{ cm}$$

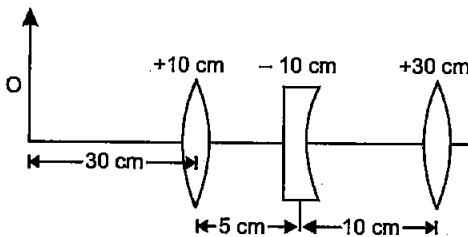

This means that image formed by first lens is at a distance of 15 cm to the right of the first lens. This image serves as the virtual object for second lens.

For second lens,

$$f_2 = -10 \text{ cm}, u = 15 - 5 = +10 \text{ cm}$$

$$\begin{aligned} \therefore \frac{1}{v_2} &= \frac{1}{f_2} + \frac{1}{u_2} \\ &= -\frac{1}{10} + \frac{1}{10} \end{aligned}$$

$$\Rightarrow v_2 = \infty$$

This means that the real image is formed by second lens at infinite distance. This acts as an object for third lens.

for third lens, $f_3 = +30$ cm, $u_3 = \infty$

$$\begin{aligned} \therefore \frac{1}{v_3} &= \frac{1}{f_3} + \frac{1}{u_3} \\ &= \frac{1}{30} + \frac{1}{\infty} \end{aligned}$$

$$\therefore v_3 = 30 \text{ cm}$$

i.e., final image is formed at a distance of 30 cm to the right of third lens.

27. (a) Describe briefly the process of transferring the charge between the two plates of a parallel plate capacitor when connected to a battery. Derive an expression for the energy stored in a capacitor.

(b) A parallel plate capacitor is charged by a battery to a potential difference V . It is disconnected from battery and then connected to another uncharged capacitor of the same capacitance. Calculate the ratio of the energy stored in the combination to the initial energy on the single capacitor. [5]

OR

(a) Derive an expression for the electric field at any point on the equatorial line of an electric dipole.

(b) The identical point charges, q each, are kept 2 m apart in air. A third point charge Q of unknown magnitude and sign is placed on the line joining the charges such that the system remains in equilibrium. Find the position and nature of Q .

Answer :

(a) When the plates of the parallel plate capacitor is connected to a battery. Then the first insulated metal plate gets, the positive charge till its potential become maximum. Then, the charge will leak to surroundings. So, the negative charge will be induced on the nearer face of the second plate and the positive charge will be induced on its farther plate.

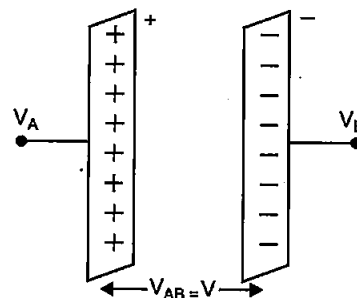

Consider a capacitor of capacitance C . Initial charge and potential difference be zero. Let, a charge Q be given in small steps. Let at any instant when charge on capacitor be q , the potential difference between its plates,

$$V = \frac{q}{C}$$

Now work done in giving an additional charge dq is,

$$dW = V dq = \frac{q}{C} dq$$

Total work done in giving charge from 0 to Q is,

$$W = \int_0^Q V dq = \int_0^Q \frac{q}{C} dq$$

$$= \frac{1}{C} \left[\frac{q^2}{2} \right]_0^Q = \frac{1}{C} \left[\frac{Q^2}{2} - \frac{0}{2} \right] = \frac{Q^2}{2C}$$

$$W = \frac{(CV)^2}{2C} = \frac{1}{2} CV^2 = \frac{1}{2} QV \quad [\because Q = CV]$$

∴ Electrostatic potential energy,

$$U = \frac{Q^2}{2C} = \frac{1}{2} CV^2 = \frac{1}{2} QV$$

(b) Here, $C_1 = C, C_2 = C$

$$V_1 = V, V_2 = 0$$

Now initially, energy stored in first capacitor, as second capacitor is uncharged.

$$\begin{aligned} U_1 &= \frac{1}{2} C V_1^2 \\ &= \frac{1}{2} C V^2 \quad \dots(i) \end{aligned}$$

Now, when C_1 and C_2 are connected the two capacitor form a parallel combination.

Equivalent capacitance,

$$C' = C_1 + C_2 = 2C$$

$$\text{Final potential} = \frac{\text{Total charge}}{\text{Total capacitance}}$$

$$V' = -\frac{q}{2C} \quad \text{[Total charge will be of first capacitor, which is distributed]}$$

$$= \frac{CV}{2C} = \frac{V}{2}$$

Final energy stored in combination,

$$U_2 = \frac{1}{2} C' V'^2 = \frac{1}{2} \times 2C \times \left(\frac{V}{2} \right)^2 = \frac{CV^2}{4} \quad \dots(ii)$$

On dividing equations (i) with (ii), we get

$$\frac{U_2}{U_1} = \frac{\frac{1}{4} CV^2}{\frac{1}{2} CV^2} = \frac{1}{2}$$

$$U_2 : U_1 = 1 : 2$$

OR

(a) Consider an electric dipole of charges $-q$ and $+q$ separated by a distance $2a$ and placed in a free space. Let P be a point on equatorial line of dipole at a distance r from the centre of a dipole.

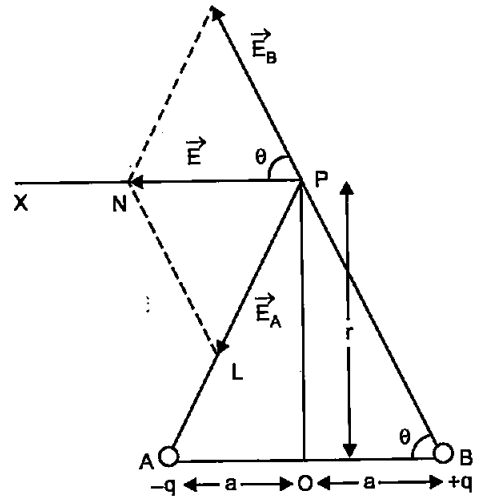

Let, \vec{E}_A and \vec{E}_B be the electric field at point P due to charges $-q$ and $+q$

Then resultant electric field at point P is

$$\vec{E} = \vec{E}_A + \vec{E}_B$$

Now,

$$|\vec{E}_A| = \frac{1}{4\pi\epsilon_0} \cdot \frac{q}{AP^2} = \frac{1}{4\pi\epsilon_0} \cdot \frac{q}{(r^2 + a^2)} \quad \text{(along PA)}$$

$$|\vec{E}_B| = \frac{1}{4\pi\epsilon_0} \cdot \frac{q}{BP^2} = \frac{1}{4\pi\epsilon_0} \cdot \frac{q}{(r^2 + a^2)} \quad \text{(along BP)}$$

The resultant intensity is the vector sum of E_A and E_B .

E_A and E_B can be resolved into two components. The Y-components cancel out each other. And X-component will add up to give the resultant field.

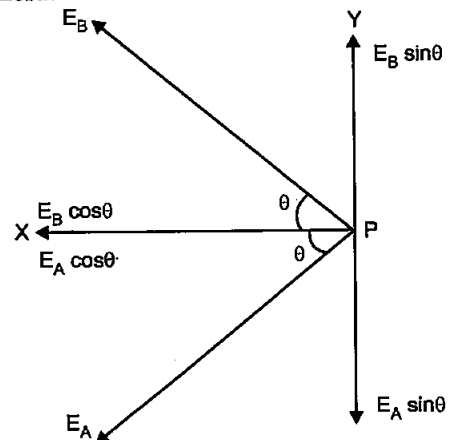

$$\therefore |\vec{E}| = E_A \cos \theta + E_B \cos \theta$$

Now in right, triangle ORB

$$\cos \theta = \frac{OB}{BP} = \frac{a}{\sqrt{r^2 + a^2}}$$

$$\therefore E = 2 \times \frac{1}{4\pi\epsilon_0} \times \frac{q}{r^2 + a^2} \cdot \frac{a}{(r^2 + a^2)^{1/2}}$$

$$= \frac{2qa}{4\pi\epsilon_0(r^2 + a^2)^{3/2}}$$

$$= \frac{1}{4\pi\epsilon_0} \frac{p}{(r^2 + a^2)^{3/2}}$$

[∵ 2qa = p]

This is the required expression.

(b) Let the two charges of +q each placed at point A and B at a distance 2 m apart in air.

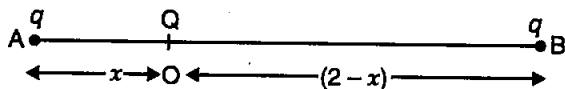

Suppose, the third charge Q (unknown magnitude and charge) is placed at a point O, on the line joining the other two charges, such that OA = x and OB = 2 - x.

For the system to be in equilibrium, net force on each 3 charges must be zero.

If we assume that charge Q placed at O is

positive, the force on it at O may be zero. But the force on charge q at point A or B will not be zero. It is because, the forces on a charge q due to the other two charges will act in same direction. If charge Q is negative, then the forces on q due to other two charges will act in opposite direction.

Hence, Q will be negative in nature.

For charge (-Q) to be in equilibrium

Force on charge (-q) due to charge (+q) at point A should be equal and opposite to charge (+Q) at B

$$\frac{1}{4\pi\epsilon_0} \frac{Qq}{x^2} = \frac{1}{4\pi\epsilon_0} \frac{Qq}{(2-x)^2}$$

or $(2-x)^2 = x^2$

⇒ $x = (2-x) \Rightarrow x = 1 \text{ m}$

Therefore, for the system to be in equilibrium a charge -Q is placed at a mid point between the two charges of +q each.

Physics 2019 (Delhi)

SET II

Time allowed : 3 hours

Maximum marks : 70

Note : Except for the following questions, all the remaining questions have been asked in previous set.

SECTION-A

2. When unpolarised light is incident on the interface separating the rarer medium and the denser medium. Brewster angle is found to be 60°. Determine the refractive index of the denser medium. [1]

Answer :

According to Brewster's law,

$$\tan i_p = n$$

Since, $i_p = 60^\circ$

∴ Refractive index of medium,

$$n = \tan 60^\circ$$

$$n = \sqrt{3}$$

$$n = 1.732$$

4. When a potential difference is applied across the ends of a conductor, how is the drift velocity of the electrons related to the relaxation time? [1]

Answer :

$$\vec{v}_d = -\frac{e\vec{E}}{m}\tau$$

e = charge of electron

E = potential difference applied

τ = relaxation time

∴ $v_d \propto \tau$ i.e. drift velocity is directly proportional to relaxation time.

5. Draw the equipotential surfaces due to an isolated point charge. [1]

Answer :

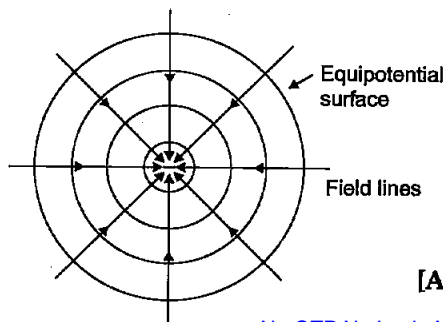
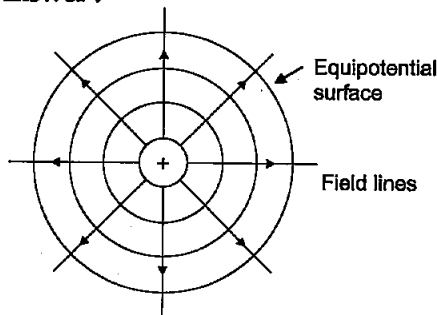

[Any one]

SECTION-B

6. Explain with the help of Einstein's photoelectric equation any two observed features in photoelectric effect which cannot be explained by wave theory. [2]

Answer :

Features of photoelectric equation which can not be explained by wave theory :

- (a) The wave theory could not explain the instantaneous process of photoelectric effect.
- (b) 'Maximum kinetic energy' of the emitted photoelectrons is independent of intensity of incident light.

7. A deuteron and an alpha particle having same momentum are in turn allowed to pass through a magnetic field \vec{B} , acting normal to the direction of motion of the particles. Calculate the ratio of the radii of the circular paths described by them. [2]

Answer :

Radius of circular path

$$r = \frac{mv}{qB}$$

i.e., $r = \frac{p}{qB}$ [$\because p = mv$]

Momentum of deuteron and alpha-particle are same and in same magnetic field

$$\therefore r_d = \frac{p}{q_d B} = \frac{p}{eB} \quad [\because q_d = q_\alpha = e]$$

$$\text{Now } r_\alpha = \frac{p}{q_\alpha B} = \frac{p}{2eB} \quad [\because q_\alpha = 2e]$$

Therefore, $r_d : r_\alpha = 2 : 1$

11. (a) Plot a graph showing variation of de Broglie wavelength (λ) associated with a charged particle of mass m , versus \sqrt{V} , where V is the accelerating potential.
 (b) An electron, a proton and an alpha particle have the kinetic energy. Which one has the shortest wavelength? [2]

Answer :

(a) We know, $\lambda = \frac{1.22 \text{ }^\circ\text{A}}{\sqrt{V}}$

$$\lambda\sqrt{V} = \text{constant}$$

The nature of the graph between λ and \sqrt{V} is hyperbola.

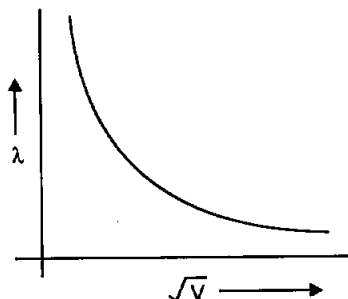

- (b) According to de-Broglie wavelength

$$\lambda = \frac{h}{\sqrt{2mE_k}}$$

For same kinetic energy,

$$\lambda_\alpha = \frac{1}{\sqrt{m}}$$

We know that

$$m_\alpha > m_p > m_e$$

Since, alpha-particle have the maximum mass. Therefore, alpha-particle will have minimum wavelength.

SECTION-C

13. (a) State the underlying principle of a moving coil galvanometer.
 (b) Give two reasons to explain why a galvanometer cannot as such be used to measure the value of the current in a given circuit.
 (c) Define the terms : (i) voltage sensitivity and (ii) current sensitivity of a galvanometer. [3]

Answer :

(a) **The Principle :** When a current flows through the conductor coil, a torque acts on it due to the external radial magnetic field. Counter torque due to suspension balances coil after appropriate deflection due to current in the circuit.

(b) A galvanometer can be used as such to measure current due to following two reasons.

(i) A galvanometer has a finite large resistance and is connected in series in the circuit, so it will increase the resistance of circuit and hence change the value of current in the circuit.

(ii) A galvanometer is a very sensitive device, it gives a full scale deflection for the current of the order of microampere, hence if connected as such it will not measure current of the order of ampere.

(c) (i) **Voltage sensitivity :** It is defined, as the deflection produced in the galvanometer when a unit voltage is applied across it.

(ii) **Current Sensitivity :** The ratio of deflection produced by the coil ϕ to the current in the coil is called the current sensitivity. It is the deflection of the meter per unit current.

15. (a) Draw equipotential surfaces corresponding to the electric field that uniformly increases in magnitude along with the z-directions.
 (b) Two charges $-q$ and $+q$ are located at point $(0, 0, -a)$ and $(0, 0, a)$. What is the electrostatic potential at the points $(0, 0, \pm z)$ and $(a, 0, 0)$? [3]

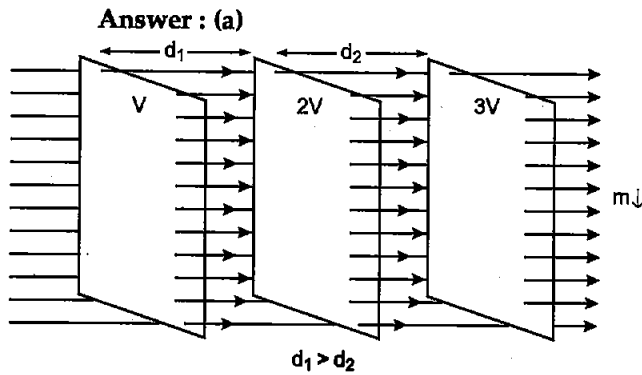

(b) Since, two charges are on Z-axis. Therefore, the electric potential on an arrival position *i.e.*, at $(0, 0, \pm 2)$ is given by

$$V_1 = \frac{1}{4\pi\epsilon_0} \times \frac{2lq}{r^2 - l^2}$$

$$= \frac{1}{4\pi\epsilon_0} \times \frac{2aq}{(z^2 - a^2)} \quad [\because l = a \because r = \pm z]$$

Now electric potential at the position $(x, y, 0)$ is given by

$$V = \frac{1}{4\pi\epsilon_0} \cdot \frac{2aq \cos \theta}{r^2}$$

But $\theta = 90^\circ$

$\therefore V_2 = 0$ at the position of $(x, y, 0)$ due to an electric dipole, placed on Z-axis.

17. (a) Write the relation between half life and average life of a radioactive nucleus.
 (b) In a given sample two isotopes A and B are initially present in the ratio of 1 : 2. Their half lives are 60 years and 30 years respectively. How long will it take so that the sample has these isotopes in the ratio of 2 : 1 ? [3]

Answer. (a) Half life period = $\frac{0.693}{\lambda} = 0.693 \tau$
 = 69.3% of average life

(b) We have, $N = N_0 e^{-\lambda t}$

For two isotopes, we can write

$$N_A = N_0 e^{-\lambda_A t_A} \quad \dots(i)$$

$$N_B = N_0 e^{-\lambda_B t_B} \quad \dots(ii)$$

Let the time be t after which,

$$\frac{N_A}{N_B} = \frac{2}{1}$$

i.e., $t_A = t_B = t$

$$\therefore N_0 e^{-\lambda_A t} = 2N_0 e^{-\lambda_B t}$$

$$\Rightarrow e^{-\lambda_A t} e^{\lambda_B t} = 2$$

$$\Rightarrow e^{\lambda_B t - \lambda_A t} = 2$$

$$\Rightarrow (\lambda_B t - \lambda_A t) = \log_e 2$$

$$\Rightarrow (\lambda_B - \lambda_A)t = \log_e 2$$

$$\Rightarrow \left[\frac{\log_e 2}{T_B} - \frac{\log_e 2}{T_A} \right] t = \log_e 2 \quad \left[\because \lambda = \frac{\log_e 2}{T} \right]$$

$$\Rightarrow \left[\frac{1}{30} - \frac{1}{60} \right] t = 1$$

$$\Rightarrow t = \frac{30 \times 60}{30} = 60 \text{ years}$$

19. (a) Define the term 'self inductance' of a coil. Write its S.I. unit.
 (b) A rectangular loop of sides a and b carrying current I_2 is kept at a distance ' a ' from an infinitely long straight wire carrying current I_1 as shown in the figure. Obtain an expression for the resultant force acting on the loop. [3]

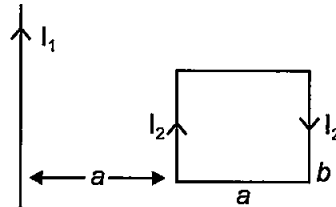

Answer :

(a) **Self-inductance :** Self-inductance of a coil is numerically equal to the amount of magnetic flux linked with the coil when and current flows through the coil.

The S.I. unit of Self-inductance is henry (H) or weber per Ampere $1 \text{ H} = 1 \text{ wb/A}$

(b) The force on the side AB of rectangle is attractive as current is flowing in the same direction and on side CD will be repulsive the current is flowing in opposite direction with respect to straight conductor. The resultant magnetic force. On sides AD and BC is zero. The side AB is the straight wire. So, the net force will be attractive and rectangular loop will move towards the straight wire.

Now, force between AB and straight wire

$$F_1 = \frac{\mu_0 I_1 I_2}{2\pi a} \quad \dots(i)$$

Force between CD and straight wire

$$F_2 = \frac{\mu_0}{2\pi} \times \frac{I_1 I_2}{(a+b)} \quad \dots(ii)$$

$$\therefore F_{\text{net}} = F_1 - F_2$$

$$= \frac{\mu_0}{2\pi} \cdot \frac{I_1 I_2}{a} - \frac{\mu_0}{2\pi} \frac{I_1 I_2}{(a+b)}$$

$$= \frac{\mu_0}{2\pi} I_1 I_2 \left[\frac{1}{a} - \frac{1}{a+b} \right]$$

$$= \frac{\mu_0}{2\pi} \times I_1 I_2 \frac{b}{a(a+b)}$$

$$F_{\text{net}} = \frac{\mu_0}{2\pi} \times \frac{I_1 I_2 b}{a(a+b)} \quad [\text{Towards the wire}]$$

Physics 2019 (Delhi)

SET III

Time allowed : 3 hours

Maximum marks : 70

Note : Except for the following questions, all the remaining questions have been asked in previous set.

SECTION-A

1. Distinguish between unpolarized and linearly polarized light. [1]

Answer :

Unpolarized light : The light having vibration of electric field vector in all possible directions perpendicular to the direction of wave propagation the light is known as unpolarized light.

Linearly polarized light : The light having vibrations of electric field vector in only one direction perpendicular to the direction of propagation of light is as plane or linearly polarized light

3. How is the drift velocity in a conductor affected with the rise in temperature ? [1]

Answer :

With the rise in temperature, the collision of electrons occurs more frequently, so relaxation time decreases and hence drift velocity increases.

$$v_d = \frac{eE}{m} \tau$$

$$v_d \propto \tau$$

5. Draw the pattern of electric field lines when a point charge +q is kept near an uncharged conducting plate. [1]

Answer : The lines of force start from +Q and terminates at metal plate inducing negative charge on it.

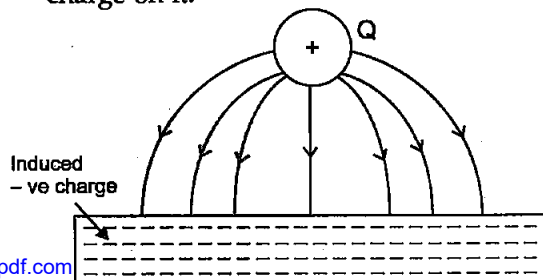

SECTION - B

6. (a) Define the terms, (i) threshold frequency and (ii) stopping potential in photoelectric effect. [2]

Answer : (a) (i) **Threshold frequency :** The minimum frequency of incident light which is just capable of ejecting electrons from a metal is called the threshold frequency. It is denoted by ν_0 .

(ii) **Stopping potential :** The minimum retarding potential applied to anode of a photoelectric tube which is just capable of stopping photoelectric current is called the stopping potential. It is denoted by V_0 (or V_s).

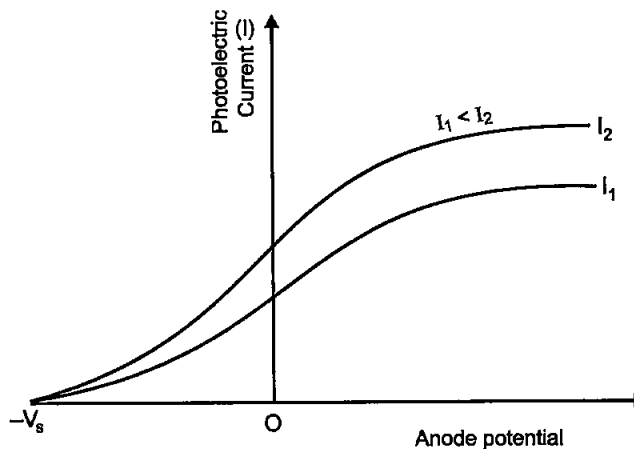

11. Obtain the expression for the ratio of the de-Broglie wavelengths associated with the electron orbiting in the second and third excited states of hydrogen atom. [2]

Answer :

According to Bohr's postulate,

$$mvr = \frac{nh}{2\pi}$$

i.e.,
$$2\pi r = \frac{nh}{mV}$$

or
$$\frac{h}{mV} = \frac{2\pi r}{n}$$

since, $\frac{h}{mv} = \frac{h}{p} = \lambda$, by de -Broglie hypothesis

Therefore, $\frac{2\pi r}{n} = \lambda$

Now for second excited state

$$\lambda_2 = \frac{2\pi r_3}{2} \quad \dots(i)$$

and for third excited state

$$\lambda_3 = \frac{2\pi r_2}{3} \quad \dots(ii)$$

on dividing equations (i) by (ii),

$$\frac{\lambda_2}{\lambda_3} = \frac{3r_2}{2r_3}$$

This is the required expression.

12. A charged particle q is moving in the presence of a magnetic field B which is inclined to an angle 30° with the direction of the motion of the particle. Draw the trajectory followed by the particle in the presence of the field and explain how the particle describes this path. [2]

Answer :

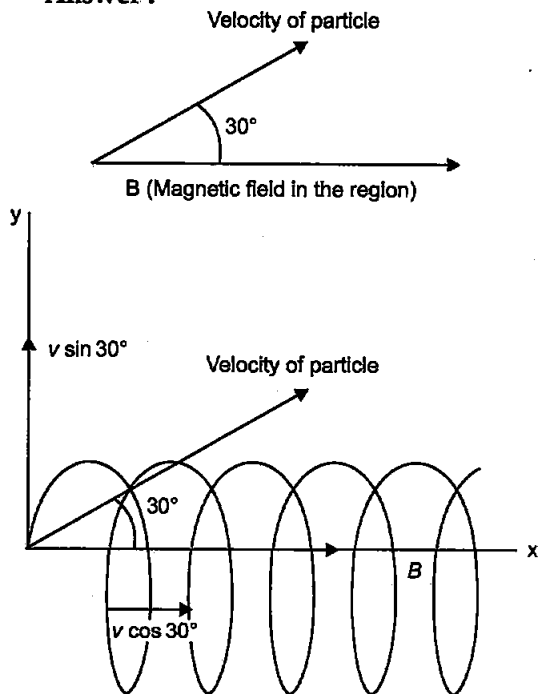

When a charged particle enter in a magnetic field making angle at 30° . Then velocity component is resolved into 2 components. $v \cos \theta$ (along the magnetic field) and $v \sin \theta$ (normal to the magnetic field).

As the charged particle moves along XY-plane due to velocity component $v \sin \theta$, it also advances linearly due to the velocity

component $v \cos \theta$. As a result, the charged particle will move in a helical path as shown in figure.

SECTION-C

13. (a) Explain briefly how Rutherford scattering of α -particle by a target nucleus can provide information on the size of the nucleus.
 (b) Show that density of nucleus is independent of its mass number A . [3]

Answer :

(a) In Rutherford's scattering experiment of α -particle, it was observed that the fast and heavy α -particles could be deflected through 180° . But only very small number of particles i.e., 1 in about 8,000 α -particles are deflected through 180° that too from centre only.

So by this it was assumed that the size of central part i.e., nucleus is about $\frac{1}{10,000}$ th of the size of the atom and whole positive charge is concentrated in it.

(b) Consider an atom whose mass number is A and R be the radius of the nucleus. If we neglect the mass of orbital electrons, then mass of the nucleus of the atom of mass number $A = A$ a.m.u.

Mass of nucleus, $m = A \times 1.66 \times 10^{-27}$ kg

Volume of nucleus,

$$V = \frac{4}{3} \pi R^3$$

$$= \frac{4}{3} \pi (R_0 A^{1/3})^3 \quad [\because R = R_0 A^{1/3}]$$

where, $R_0 = 1.1 \times 10^{-15}$, range of nuclear force

Therefore, $V = \frac{4}{3} \pi (1.1 \times 10^{-15})^3 \times A m^3$

Density of nucleus, $\rho = \frac{\text{Mass of nucleus}}{\text{Volume of nucleus}}$

$$= \frac{A \times 1.66 \times 10^{-27}}{\frac{4}{3} \pi (1.1 \times 10^{-15})^3 \times A} \times A$$

$$= 2.97 \times 10^{17} \text{ kg/m}^3$$

Therefore density of nucleus is independent of mass number.

14. State the underlying principle of a cyclotron. Explain its working with the help of a schematic diagram. Obtain the expression for cyclotron frequency. [3]

Answer :

(a) Principle : It is based on a principle that a positive ion can acquire sufficiently large energy with a comparatively smaller alternating potential difference by making it to cross the same electric field again and again by making use of a strong magnetic field.

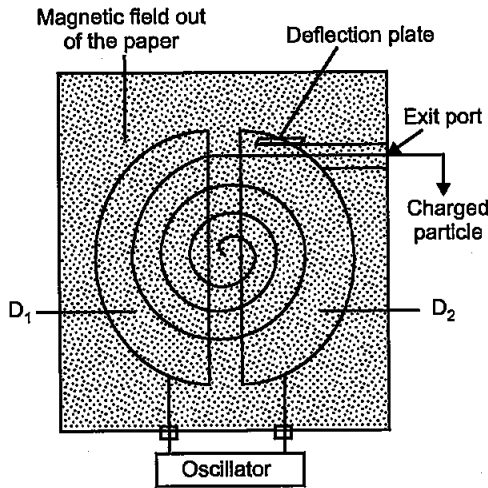

Working : The positive ions are produced from the source at the centre are accelerated by a dee which is at negative potential at that moment. Due to the presence of perpendicular magnetic field the ion will move in a circular path inside the dees. The magnetic field and the frequency of a.c source are so chosen that as the ions comes out of a dee, it changes its polarity and the ion is further accelerated and moves with higher velocity along a circular path of greater radius. This phenomenon is continued till the ion reaches at the periphery of the dees where an deflecting plate deflects the accelerated ion on the target to be bombarded.

Expression for cyclotron frequency

Suppose a position ion with charge q moving with a velocity v , then

$$qvB = \frac{mv^2}{r}$$

or

$$r = \frac{mv}{qB}$$

Therefore, angular velocity ω is

$$\omega = \frac{v}{r} = \frac{qB}{m}$$

The time taken by ion in describing a semi circle is (i.e., an angle π)

$$t = \frac{\pi}{\omega} = \frac{\pi m}{qB}$$

This is a semi-periodic time ($T/2$)

$$\therefore \frac{T}{2} = t = \frac{\pi m}{qB}$$

i.e., $T = \frac{2\pi m}{qB}$, time period of revolution

\therefore Frequency of revolution is

$$f = \frac{1}{T} = \frac{qB}{2\pi m}$$

This frequency is called the cyclotron frequency.

15. Two infinitely long straight wire A_1 and A_2 carrying currents I and $2I$ flowing in the same direction are kept ' d ' distance apart. Where should a third straight wire A_3 carrying current $1.5I$ be placed between A_1 and A_2 so that it experiences no net force due to A_1 and A_2 ? Does the net force acting on A_3 depend on the current flowing through it? [3]

Answer :

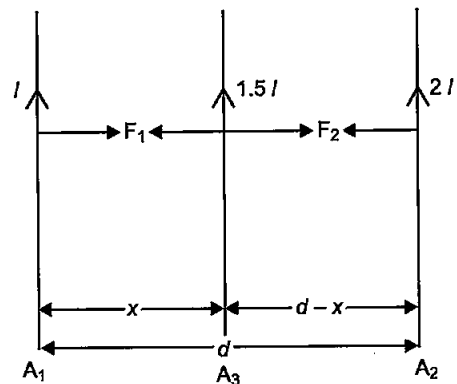

Let the wire A_3 placed at a distance x from the wire A_1 . And the distance of wire A_3 from A_2 be $(d - x)$ The current flowing through them is I , $1.5I$ and $2I$ in A_1 , A_3 and A_2 respectively. Let the current flowing in the wire A_3 be in the same direction as A_1 and A_2 .

Therefore, force between A_1 and A_3 is,

$$F_1 = \frac{\mu_0}{2\pi} \cdot \frac{I \times 1.5I}{x} \quad \dots(i)$$

Force between A_3 and A_2 is,

$$F_2 = \frac{\mu_0}{2\pi} \cdot \frac{2I \times 1.5I}{(d-x)} \quad \dots(ii)$$

Since, the net force on A_3 is zero,

$$\therefore F_1 = F_2$$

$$\Rightarrow \frac{\mu_0}{2\pi} \times \frac{I \times 1.5 I}{(x)} = \frac{\mu_0}{2\pi} \times \frac{2 I \times 1.5 I}{(d-x)}$$

$$\Rightarrow \frac{1.5}{x} = \frac{3}{d-x}$$

$$\Rightarrow 1.5 d - 1.5x = 3x$$

$$\Rightarrow 4.5 x = 1.5 d$$

$$\text{Therefore, } x = \frac{d}{3}$$

The wire A_3 is placed at a distance of $\frac{d}{3}$ from A_1 and $\frac{2d}{3}$ from A_2 .

No, at a same distance the force on the wire A_3 is independent of the direction of the current. As if current is in opposite direction then F_1 and F_2 will be in opposite direction, but will be in equilibrium.

16. (a) Draw the equipotential surfaces due to an electric dipole.
 (b) Derive an expression for the electric field due to a dipole of dipole moment \vec{p} if at a point on its perpendicular bisector. [3]

Answer : (a)

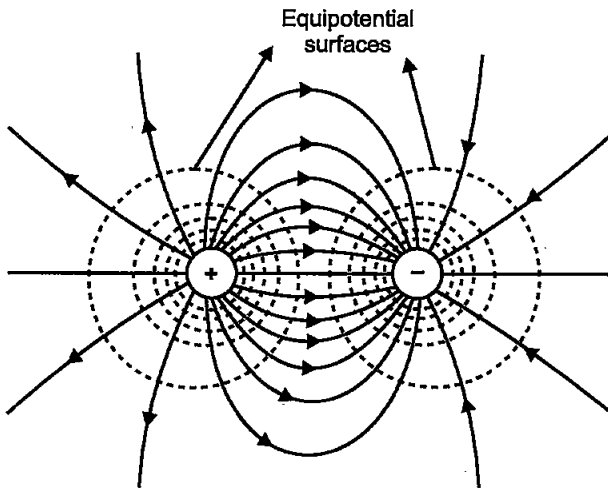

(b)

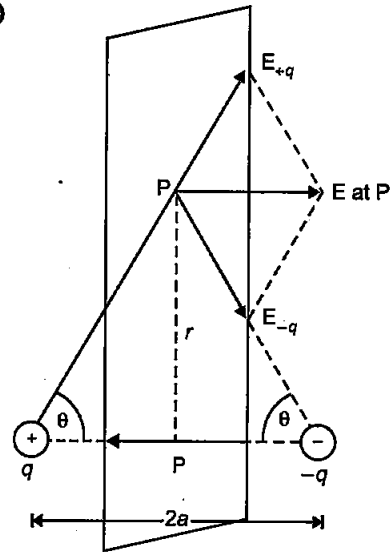

The Magnitudes of the electric field due to the two charges $+q$ and $-q$ given by.

$$E_{+q} = \frac{q}{4\pi\epsilon_0} \frac{1}{r^2 + a^2} \quad \dots(i)$$

$$E_{-q} = \frac{q}{4\pi\epsilon_0} \frac{1}{r^2 + a^2} \quad \dots(ii)$$

$$\therefore E_{+q} = E_{-q}$$

The directions of E_{+q} and E_{-q} are as shown in the figure. The components normal to the dipole axis cancel away. The components along the dipole axis add up.

\therefore Total electric field

$$E = -(E_{+q} + E_{-q}) \cos \theta \hat{p} \quad [\text{Negative sign shows that field is opposite to } \hat{p}]$$

$$E = -\frac{2qa}{4\pi\epsilon_0(r^2 + a^2)^{3/2}} \hat{p} \quad \dots(iii)$$

At large distances ($r \gg a$), this reduces to

$$E = -\frac{2qa}{4\pi\epsilon_0 r^3} \hat{p} \quad \dots(iv)$$

$$\therefore \vec{p} = q \times 2a \hat{p}$$

$$\therefore E = \frac{-\vec{p}}{4\pi\epsilon_0 r^3} \quad (r \gg a)$$

••

Students don't need to purchase any Guide, Question Bank or Sample/model paper from market. All material will be available on this website in the form of free PDFs by 30 September. On website www.cbsepdf.com following materials will be provided :

1. NCERT Solutions
2. Previous Years Papers (2011-2019)
3. Previous Years Chapterwise Question Bank
4. 20 Solved Sample Paper

Students can download from following website

www.cbsepdf.com

A mission for free content for all.